

Current Hand Exoskeleton Technologies for Rehabilitation and Assistive Engineering

Pilwon Heo¹, Gwang Min Gu¹, Soo-jin Lee², Kyehan Rhee² and Jung Kim^{1,#}

¹ Department of Mechanical Engineering, Korea Advanced Institute of Science and Technology, 291 Daehak-ro, Yuseong-gu, Daejeon, Republic of Korea, 305-701
² Department of Mechanical Engineering, College of Engineering, Myongji University, 116 Myongji-ro, Choin-gu, Yongin, Gyeonggi-do, Republic of Korea, 449-728
Corresponding Author / E-mail: jungkim@kaist.ac.kr, TEL: +82-42-350-3231, FAX: +82-42-350-5230

KEYWORDS: Hand exoskeleton, Rehabilitation, Assistance

In this paper, we present a comprehensive review of hand exoskeleton technologies for rehabilitation and assistive engineering, from basic hand biomechanics to actuator technologies. Because of rapid advances in mechanical designs and control algorithms for electro-mechanical systems, exoskeleton devices have been developed significantly, but are still limited to use in larger body areas such as upper and lower limbs. However, because of their requirements for smaller size and rich tactile sensing capabilities, hand exoskeletons still face many challenges in many technical areas, including hand biomechanics, neurophysiology, rehabilitation, actuators and sensors, physical human-robot interactions and ergonomics. This paper reviews the state-of-the-art of active hand exoskeletons for applications in the areas of rehabilitation and assistive robotics. The main requirements of these hand exoskeleton devices are also identified and the mechanical designs of existing devices are classified. The challenges facing an active hand exoskeleton robot are also discussed.

Manuscript received: March 7, 2012 / Accepted: April 15, 2012

1. Introduction

Because of their inherent motor and sensory requirements, hand exoskeleton technologies for rehabilitation and assistive engineering have not progressed as rapidly as the exoskeleton robots and devices for lower and upper limbs that have become popular over the last decade. These requirements have inspired considerable developments in robotic hands in terms of their degrees of freedom, weight, size and dexterous manipulation capabilities. At the same time, enhancement of hand functions using exoskeleton technologies for those who have lost or weakened hand capabilities because of neuromuscular diseases or aging has become an important issue, because hand functionality is a dominant factor in living an independent and healthy life.

From the viewpoint of rehabilitation after a stroke, it is important for the patient to take intensive and continuous therapeutic exercise for successful rehabilitation. It is shown that recovery from a brain injury is greatly influenced by the sensorimotor experience after the injury.¹ Highly repetitive training can also help to recover the motor function.^{2,3} However, conventional therapy for stroke rehabilitation requires manual interaction with physical therapists that make the procedure labor-intensive and raise the costs. Also, the quantitative evaluation

of the patient's performance and progress is difficult with manual therapy. The efforts to overcome the inefficiency of conventional therapy have been realized by robotic rehabilitation. It has been shown that robotic repetitive movement training might be a more effective treatment, especially for patients who have difficulty in performing unassisted repetitive motion.⁴ These robotic rehabilitation systems can provide effective repetitive training for rehabilitation without significantly increasing the costs. The robotic system can also be used to evaluate the progress quantitatively. These advantages make the use of hand exoskeletons for rehabilitation applications look promising.

Even after an intensive rehabilitation process, hand function may not be recovered fully. In fact, up to 66% of hemiplegic stroke patients have not regained the function of the paretic arm when measured 6 months after the stroke, while only 5% to 20% of patients show complete functional recovery.⁵⁻⁸ Hand exoskeletons can be used to assist the patients who have suffered permanently lost or weakened hand function.

Also, people whose work requires the exertion of a forceful and repetitive hand gripping action are exposed to a high likelihood of developing a musculoskeletal disorder. Therefore, to prevent such work-related musculoskeletal disorders, it is important to reduce the physical burden on these workers. Hand exoskeletons can be used

to assist the hand function by amplifying the hand gripping force or automating the motion. Applicable areas include heavy industry, construction, military, and logistics.

In the following section, the biomechanics of the hand are discussed and the requirements for the exoskeleton devices are presented. In Section 3, hand exoskeletons for rehabilitation and assistance applications that have been developed or are under development are introduced. Actuator technologies and intention sensing methods are discussed in Sections 4 and 5, respectively. Finally, Section 6 summarizes the article and briefly discusses the challenges facing hand exoskeleton development.

2. Hand Biomechanics

2.1 Anatomy of the Hand

Because a mechanism of a hand exoskeleton is closely coupled with a hand when it is worn, developing the hand exoskeleton requires an understanding of hand anatomy and biomechanics for ensuring safe and effective operation. Specifically, considering the DOF (degree of freedom) and ROM (range of motion) of each joint is important for the design of mechanically safe structure. In addition, the hand movement is complexly related to the intrinsic and the extrinsic muscles as well as the connective tissues. Therefore the systematic knowledge helps achieving proper functions for rehabilitation and assistance.

2.1.1 Bones and Joints

The bones of the hand are naturally grouped into the carpus, comprising the eight bones which make up the wrist and root of the hands, and the digits, each of which is composed of its metacarpal and phalangeal segments. The five digits are named as follows from the radial to the ulnar side: thumb, index finger, middle finger, ring finger, and little finger. Each finger ray is composed of one metacarpal and three phalanges, except for the thumb (which has two phalanges). There are 19 bones and 14 joints distal to the carpals, as shown in Fig. 1. The carpal bones are arranged in two rows, with those in the more proximal row articulating with the radius and ulna. Between the two is the intercarpal articulation. Each finger articulates proximally with a particular carpal bone at the carpometacarpal (CMC) joint. The CMC joint of the thumb is a sellar joint, exhibiting two degrees of freedom: flexion and extension, and abduction and adduction. The CMC joints of the fingers are classified as plane joints with one degree of freedom, while the fifth CMC joint is often classified as a semi-saddle joint with conjunctural rotation.⁹ The next joint of each finger links the metacarpal bone to the proximal phalanx at the metacarpophalangeal (MCP) joint. MCP joints are classified as ellipsoidal or condylar joints with two degrees of freedom,¹⁰ which again permit flexion, extension, abduction, and adduction movements. In MCP joints, the metacarpal heads fit into shallow cavities at the base of the proximal phalanges.¹¹ The proximal interphalangeal (PIP) and distal interphalangeal (DIP) joints are found between the phalanges of the fingers; the thumb has only one

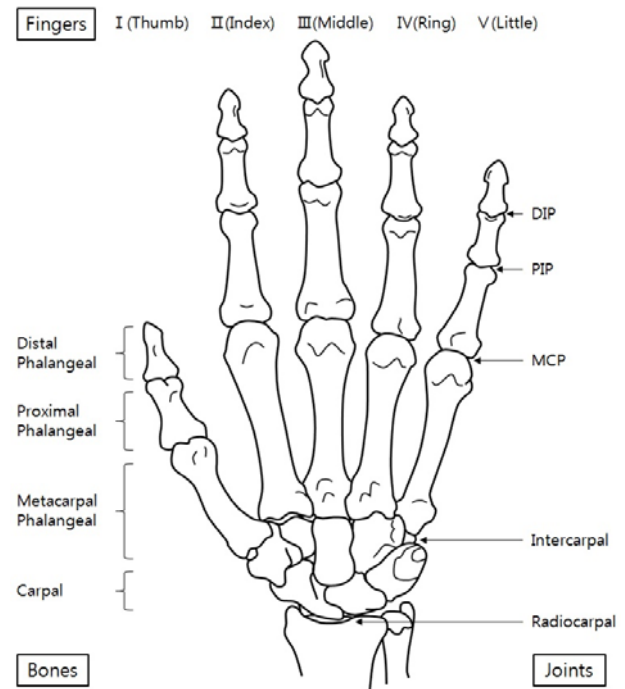

Fig. 1 Bones and joints of a human hand

interphalangeal (IP) joint. They are both bicondylar joints with subsequently greater congruency between the bony surfaces, and have one degree of freedom. The transverse diameters of the IP joints are greater than their antero-posterior diameters and the thick collateral ligaments are tight in all positions during flexion, contrary to those in the MCP joint.¹² Although the IP joints are frequently modeled and assumed as having single axis of rotation for simplicity, in fact they do not remain constant during flexion and extension.¹³

The different shapes of the finger joints result in varying DOF at each joint. Also, the orientation of the thumb and the unique configuration of its CMC joint provide this digit with a large range of motion and greater flexibility.^{14,15} The wrist is extended 20° in neutral radial/ulnar deviation at the resting posture. The resting posture is a position of equilibrium without active muscle contraction. The MCP joints are flexed approximately 45°, the PIP joints are flexed between 30° and 45°, and the DIP joints are flexed between 10° and 20° at the resting posture. Flexion of the MCP joints is approximately 90°, and the little finger is the most flexible (at about 95°), while the index finger is the least flexible (at about 70°).¹⁶ The extension varies widely among individuals. For PIP and DIP joints, flexion of about 110° and 90° occurs. Extension beyond the zero position is regularly observed and depends largely on the ligamentous laxity.

2.1.2 Muscles

Dexterous movements of the hand are accomplished by the coordinated action of both the extrinsic and intrinsic musculature. The extrinsic muscles originate from the arm and forearm, and they are responsible for flexion and extension of the digits. The intrinsic muscles are located entirely within the hand, and they permit the independent action of each digit.¹⁷ There are nine extrinsic muscles,

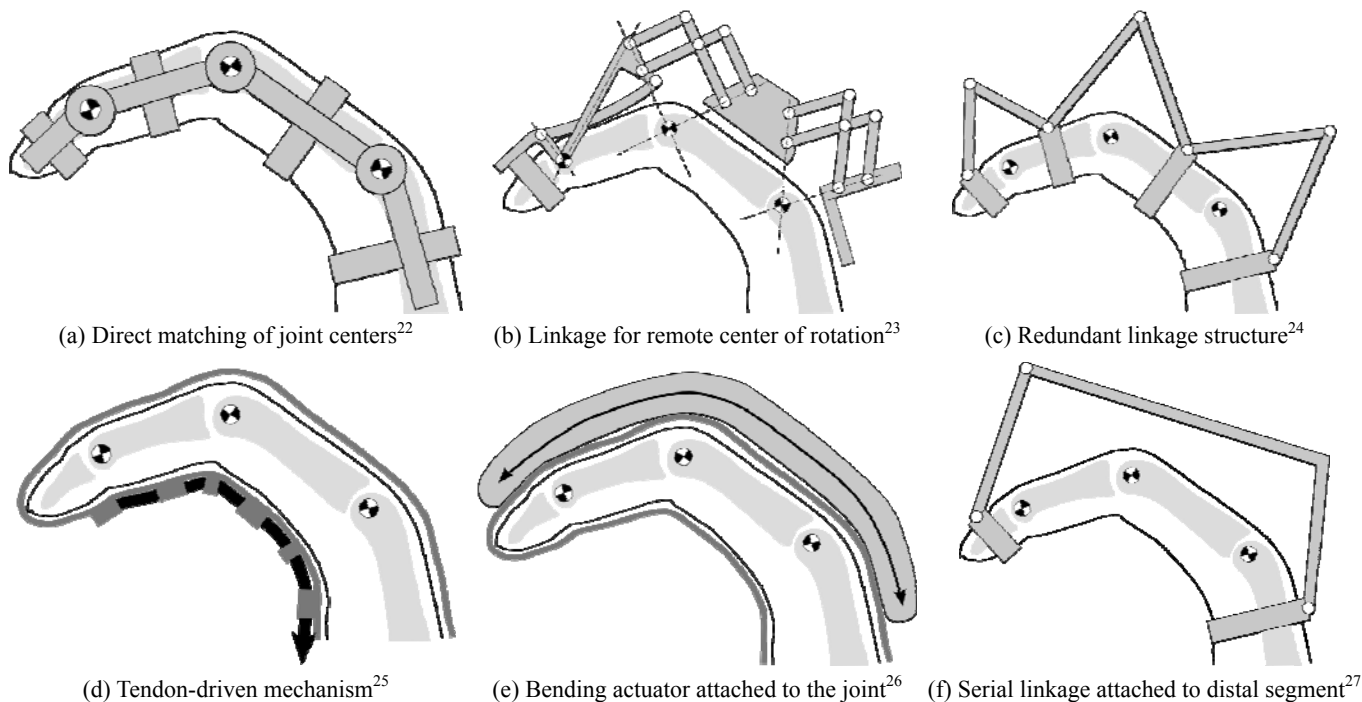

Fig. 2 Mechanisms for matching the center of rotation or eliminating the need for precise alignment

and three muscles among them - the flexor digitorum superficialis, the flexor digitorum profundus, and the flexor pollicis longus - contribute to finger flexion. Five extrinsic muscles contribute to the extension of the fingers, while one extrinsic muscle (abductor pollicis longus) contributes to the abduction of the thumb. The dorsal interossei (DI) and palmar interossei (PI) are groups of muscles arising between the metacarpals and attached to the base of the proximal phalanges or to the extensor assembly. The interossei flex the MCP joint and extend the PIP and DIP joints. They are also effective abductors and adductors, and produce some rotations of the MCP joint. Because of this interaction between the extrinsic and intrinsic musculature, the actions of the PIP and DIP joints are functionally coupled.

2.1.3 Tendons and Ligaments

As a digit moves, each tendon slides a certain distance. This excursion takes place simultaneously in the flexor and extensor tendons.¹⁸ The relationships between the excursions of the finger tendons and the angular displacements of the MCP, PIP, and DIP joints have been reported to be both linear and nonlinear.¹⁹ The excursions are larger in the more proximal joints. Also, the excursion of the flexor tendons is larger than that of the extensor tendons, and the excursion of the extrinsic muscle tendons is larger than that of the intrinsic tendons.

There are a number of important extracapsular and capsular ligaments that support and stabilize the hand. The most important extracapsular ligament is the transverse intermetacarpal ligament (TIML). It attaches to and runs between the volar plates at the level of the metacarpal heads across the entire width of the hand. The capsular collateral ligaments provide important joint stability to all of the finger and thumb joints. The MCP joint ligaments have dual attachments: bony and glenoid. The glenoid portion arises from the

metacarpal head and attaches to the volar plate, while the collateral portion arises from the metacarpal head and attaches to the base of the phalanx. In contrast, the PIP and DIP joint collateral ligaments attach completely to the bones. The collateral ligaments of the PIP and DIP joints are concentrically placed and are of equal length,^{20,21} therefore, these ligaments are maximally taut throughout their range of motion.

2.2 Requirements of the Hand Exoskeleton

One of the most important requirements of any device that interacts with humans is safety. Because the exoskeleton devices move under close contact conditions with the wearer, any malfunction can be seriously harmful to the user. Mechanical designs should therefore consider the possibilities of unpredicted erroneous operation of the device controller when the device is actively actuated. Limits to the range of motion can be set using a mechanical stopper or corresponding structural designs so that the exoskeleton cannot force the wearer's body to move in an excessive range of motion.

The coincidence of the center of rotation is a primary concern in the mechanical design of hand exoskeletons. When the user wears a hand exoskeleton with rigid linkages, the linkage structure should be designed to have a center of rotation that coincides with the rotational axis of the human body joint. Otherwise, the difference in the rotational axes may cause a collision between the user's hand and the device, resulting in damage to the user's hand.

The most intuitive method is to build the exoskeleton's center of rotation to coincide with that of the wearer.²² However, this requires an additional space to locate the mechanism at the side of the finger, making it difficult to build a multi-fingered structure. Otherwise, a remote center of rotation can be adopted. There are various applicable mechanisms for the remote center of rotation for

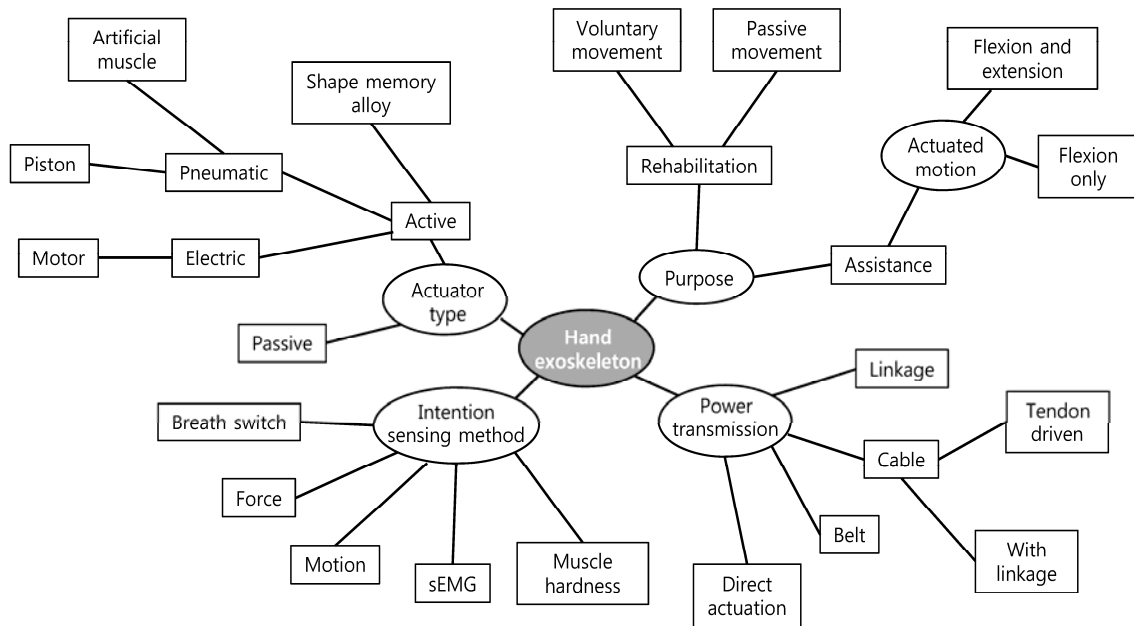

Fig. 3 Classification of hand exoskeletons according to the various criteria

this purpose.^{23,28,29} However, the consideration of the coincidence of the rotational axis can be disregarded when a flexible or underactuated structure is adopted. For example, a linkage structure with redundant degrees of freedom can be used.²⁴ In this mechanism, the number of DOFs of the linkage structure connecting the adjacent finger segments is 2 while that of human finger IP joint is only 1. The redundancy is eliminated by the constraints given when attaching the device to the user's hand. A tendon-driven mechanism mimicking the actuation of the actual human hand can also be used for the actuation of the hand exoskeleton.^{25,30} Soft pneumatic actuators directly attached to the joint of a glove work in the same way.²⁶ In these cases, where the flexible or underactuated structure is adopted, the wearer's hand actually provides a skeletal structure for the motion of the exoskeleton device. In addition, a serial linkage mechanism which is attached only to the distal segment of the finger also does not need the alignment of joint axis.²⁷ Fig. 2 shows the mechanisms described for matching the center of rotation or bypassing the problem.

Also, especially for the exoskeletons for assistance applications, building a lightweight exoskeleton device and supporting components must be considered a high priority. The power transmission method and actuation mechanism must also be considered with the structure as dominant factors in the design.

In addition to the factors described, the method for sensing the user's intended motion is also a critical consideration and is closely coupled with the device design. This will be further discussed later in the paper in a dedicated section for intention sensing methods.

3. Review of Hand Exoskeletons

Several research groups have developed hand exoskeletons for rehabilitation and assistance applications. The rehabilitation

exoskeletons provide exercise for the patients to help recovering motor function of hand. The rehabilitation exercise can be either passive movement driven by the exoskeleton or active movement against the resistive force given by the exoskeleton. Therefore the use of sensors and actuators is not mandatory but depends on the specific functions that are needed. On the other hand, the assistive exoskeletons acquire the user's motion intention and assist the user performing the action. This functionality makes it necessary to be equipped with sensors and actuators.

The hand exoskeletons can be classified using various criteria, such as actuator type, power transmission method, degrees of freedom (DOF), intention sensing method, and control method. According to these criteria, hand exoskeletons can be classified as shown in Fig. 3. Among them, the type of actuator is selected as a major criterion for classification in this paper. Table 1 shows the passive exoskeleton. Table 2 and Table 3 show the rehabilitation exoskeletons driven by electric actuators and pneumatic actuators, respectively. In the same manner, Table 4, Table 5, and Table 6 show the assistive exoskeletons driven by electric actuators, pneumatic actuators, and shape memory alloy, respectively.

3.1 Exoskeletons for Rehabilitation

3.1.1 Driven by Passive Actuator

3.1.1.1 HandSOME³¹ (Fig. 4(a))

The Hand Spring Operated Movement Enhancer (HandSOME) is a passively operated device for giving an extension moment to the finger joints so that it compensates for the finger flexor hypertonia caused by a stroke. It is designed to follow the normal kinematic trajectory of the hand during pinch-pad grasping, providing an extension torque profile that best compensates for the finger flexor hypertonia. A 4 bar linkage mechanism was designed for the thumb and finger parts to coordinate the natural grasping motion. The attachment point of the spring can be changed to adjust the torque profile.

Table 1 Rehabilitation exoskeleton driven by passive actuator

Reference	Force transmission	DOF	Note
HandSOME (Brokaw et al.) ³¹	Linkage	1	Exert extension torque for compensating finger flexor hypertonia

Table 2 Rehabilitation exoskeletons driven by electric actuators

Reference	Force transmission	Active DOF	Intention sensing method	Note
WaveFlex (Otto Bock) ³²	Linkage	1		CPM
Kinetec Maestra Portable Hand CPM (Patterson Medical) ³³	Linkage	1		CPM
Mulas et al. ³⁴	Cable	2	EMG	Active control
Tong et al. ³⁵	Linear actuator	5	EMG	CPM / Active motion
HEXOSYS (Iqbal et al.) ³⁶	Linkage	2		Underactuated
HEXORR (Schabowsky et al.) ³⁷	Linkage	2	Torque sensor	CPM / Active motion
HANDEXOS (Chiri et al.) ^{38,39}	Cable, crank-slider	5		Underactuated
Wege et al. ^{24,40}	Cable	20	EMG electrode	Active motion
Ueki et al. ⁴¹	Linkage	18	Joint angles of healthy hand	Self-motion control
iHandRehab (Li et al.) ⁴²	Cable	8	Force sensor	CPM / Active motion
Sarakglou et al. ⁴³	Cable	7		Virtual reality exerciser
AFX (Jones et al.) ⁴⁴	Cable, linkage	3		
IntelliArm (Ren et al.) ⁴⁵	Linkage	1 for hand		Passive / assistive

Table 3 Rehabilitation exoskeletons driven by pneumatic actuators

Reference	Force transmission	Active DOF	Intention sensing method	Note
Hand Mentor (Kinetic Muscles) ⁴⁶	Linkage	1		Passive / assistive
HWARD (Takahashi et al.) ⁴⁷	Linkage	3		Assistive
Wu et al. ⁴⁸	Cable, linkage	2	Force sensor	Assistive

Table 4 Assistive exoskeletons driven by electric actuators

Reference	Force transmission	Active DOF	Intention sensing method	Note
Martinez et al. ^{49,50}	Cable	3	FSR	Underactuated Passive extension
OHAe (Baker et al.) ⁵¹	Cable	3	FSR	Underactuated
Hasegawa et al. ^{52,53}	Cable	11	EMG	Finger tracking for back-drivability
In et al. ³⁰	Cable attached to glove	1	EMG	Underactuated Passive extension
In et al. ²⁵	Cable attached to glove	1		Underactuated Passive extension, Differential mechanism
Shields et al. ⁵⁴	Cable, linkage	3	Force sensors	Passive extension
SkilMate (Yamada et al.) ⁵⁵	Steel belt	3	Joint angle	Equipped with tactile sensor at fingertip
Benjuya et al. ⁵⁶	Flexible shaft	1	EMG	

Table 5 Assistive exoskeletons driven by pneumatic actuators

Reference	Force transmission	Active DOF	Intention sensing method	Note
DiCicco et al. ^{57,58}	Cable, linkage	2	EMG	Passive extension
Sasaki et al. ⁵⁹	Directly attached to glove	6	Expiration switch or tactile sensor	Underactuated Passive extension
Kadowaki et al. ²⁶	Directly attached to glove	6	Flexion angle or EMG	Underactuated
Tadano et al. ⁶⁰	Directly attached beneath the finger linkage	5	Force sensor	Underactuated Passive extension
Takagi et al. ⁶¹	Linkage	3	Bending sensor	Passive extension
Toya et al. ⁶²	Directly attached to glove	4	Estimate from movement pattern	Passive extension
Moromugi et al. ⁶³	Linkage	1	Muscle hardness sensor	

Table 6 Assistive exoskeleton driven by shape memory alloy

Reference	Force transmission	Active DOF	Intention sensing method	Note
Makaran et al. ⁶⁴	Linkage	1	Sip-and-puff switch or EMG	Passive extension

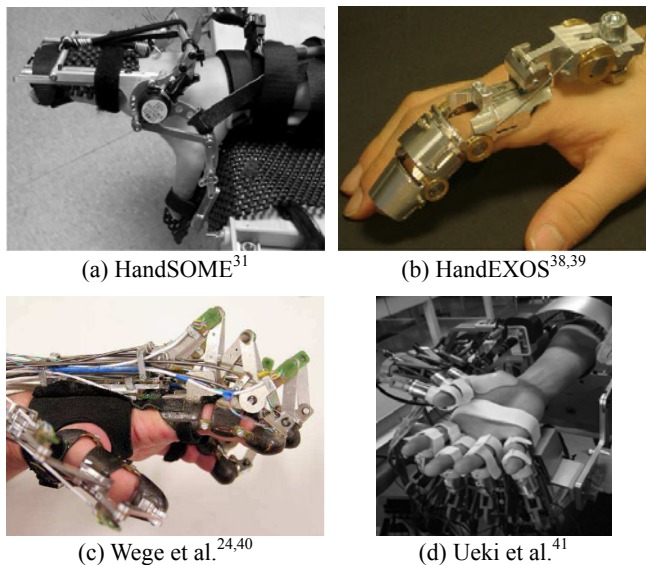

Fig. 4 Some of the hand exoskeletons for rehabilitation

3.1.2 Driven by Electric Actuator

3.1.2.1 WaveFlex³²

The WaveFlex (Otto Bock, Germany) is a commercial continuous passive movement (CPM) device for physical therapy of the hand. An electric motor is used for actuation. This device achieves a full range of motion (ROM) of flexion and extension using a drive bar and finger attachments to assist the fingers through a natural path for a grasping motion. The WaveFlex is portable and lightweight, enabling it to be worn for extended periods of time, and is adjustable for different finger lengths using the attached finger clips. The WaveFlex is also able to measure the interaction force. When the interaction force exceeds a certain threshold during motion, the 'reverse-on-load' function controls the device to move in the reverse direction to prevent overloading of the user's fingers. The user can also use this device to exercise the thumb. However, it is not possible to move the thumb simultaneously with the other fingers.

3.1.2.2 Kinetec Maestra Portable Hand CPM³³

The Kinetec Maestra Portable Hand CPM (Patterson Medical, USA) is a commercial CPM device for hand rehabilitation. It incorporates a bilateral Alumafoam splint for attachment of the device to the user's forearm. Flexion and extension movements are made via a drive bar to which the 4 fingers other than the thumb are connected together. The drive bar is actuated using an electric motor. The device can provide hyperextension and full flexion for the fingers, but thumb movement is not involved.

3.1.2.3 Mulas et al.³⁴

A device developed by Mulas et al. is actuated using two electric motors that drive wires to flex the thumb and the other fingers. Extensions are performed using springs. Unlike the CPM devices, this device is controlled based on an electromyography (EMG) signal to start the movements according to the user's volition. When the EMG signal exceeds a certain threshold, the flexion movement is initiated.

3.1.2.4 Tong et al.³⁵

Tong et al. presented a hand exoskeleton which consists of 5 finger assemblies where each finger has 1 active DOF actuated by a linear actuator, causing coupled movement of the MCP and PIP joints.

The device has 4 modes of operation: 1) CPM, 2) EMG-triggered motion, 3) continuous EMG-driven motion, and 4) free-running. In the second mode, the device starts flexion or extension motion when the corresponding EMG signal exceeds a certain threshold. In the third mode, the movement continues as long as the user's effort exists. The fourth mode selects flexion or extension of the device according to a comparison of the EMG signals from the two muscles that represent flexion and extension.

3.1.2.5 HEXOSYS³⁶

Iqbal et al. proposed the Hand EXOskeleton SYStem (HEXOSYS), which actuates 2 fingers for rehabilitation. Each finger is driven by using an underactuated linkage driven by an electric motor. The linkage structure adopted in this device is a three-link planar underactuated mechanism having a single attachment point. A custom-made force sensor is integrated into the connecting link.

3.1.2.6 HEXORR³⁷

The Hand Exoskeleton Rehabilitation Robot (HEXORR) developed by Schabowsky et al. consists of two modular components; one is for the fingers, while the other is for the thumb. The finger module is built with a four-bar linkage that is capable of providing coupled rotations of the MCP and PIP joints. Each module is driven by an electric motor and the user's movement volition is sensed using a torque sensor.

This device has three modes of operation: 1) CPM, 2) active unassisted movement, and 3) active force assisted movement. In the second mode, the device compensates for the weight and friction of the device itself, while rejecting unintentional movement commands. The third mode provides assistance for extension movements.

3.1.2.7 HANDEXOS^{38,39} (Fig. 4(b))

The hand exoskeleton developed by Chiri et al. has 5 independent modules for the fingers. Each module is composed of 3 links for the phalanges, where the center of rotation of each connection is matched with the corresponding joint of the human finger. The flexion and extension of the MCP joint is driven by a slider-crank-like mechanism, while the PIP and DIP joints are driven by Bowden cable transmissions. The 3 joints of each finger are underactuated because they are driven using a single actuator unit.

For the finger module, 3 force sensors are mounted on the surface of the inner side of each of the three palmar shells to sense the interaction force. The linear slider for MCP rotation is equipped with strain gauges to measure the force transmitted by the driving cable.

3.1.2.8 Wege et al.^{24,40} (Fig. 4(c))

The hand exoskeleton developed by Wege et al. actuates each joint via a Bowden cable driven by an electric motor. Bidirectional movement is supported by the use of two pull cables for each joint, diverted by a pulley on both ends. Only one motor is used for each joint, which introduces some slackness when compared to a solution using one motor for each direction. The motion is applied through a leverage construction on each finger attachment.

This device is controlled by EMG signals. Each finger rests in its relaxed position when no muscle activation is measured. Depending on the muscle activation, a linear force is calculated and the fingers are moved as if acting against a constant friction. The movements of the MCP, PIP, and DIP joints are performed in a coupled motion.

3.1.2.9 Ueki et al.⁴¹ (Fig. 4(d))

Ueki et al. proposed a hand exoskeleton for hemiplegic patients. The device is capable of 18 DOF motions: 3 DOF for each finger, 4 DOF for the thumb, and 2 DOF for the wrist. For each finger, 3 electric motors assist the flexion/extension of the MCP and PIP joints and the abduction/adduction of the MCP joint. For the thumb, there are 3 motors for flexion/extension and one for opposition. The wrist motion is performed using 2 motors.

The device is controlled to reproduce the movements of a healthy arm. A data glove is used to measure the joint angles of a healthy arm and the hand exoskeleton mimics the measured joint motion.

3.1.2.10 iHandRehab⁴²

The iHandRehab proposed by Li et al. aims to satisfy the requirements for both active and passive movements for hand rehabilitation. This device has finger modules for the index finger and thumb. The index finger part consists of the MCP (2 DOF), PIP (1 DOF), and DIP (1 DOF) modules, and the thumb consists of the CMC (2 DOF), MP (1 DOF), and IP (1 DOF) modules. All actuated joints are driven by cable transmissions. To realize bidirectional movement, two cables were used for each joint motion.

This device can operate in passive, active, and assisted modes. In the active modes, a force control scheme is implemented to exert a resistive force on the user's fingers. Force sensors are used to measure the interaction forces at the fingertips. The assisted mode switches from the active mode to the passive mode during the exercise.

3.1.2.11 Sarakoglou et al.⁴³

Sarakoglou et al. developed a hand exoskeleton to provide physiotherapy regimes in an interactive virtual environment. This device provides facilities for hand motion tracking, recording and analysis as well as the ability to execute both occupational and physical therapy exercises. It provides 7 active DOF: 2 for each finger except for the thumb (1 DOF). The device is actuated by pulling cables driven by electric motors located at the motor site. To measure the interaction forces, force sensors are also installed at the motor site.

This device can be used for virtual reality based physical exercise, where a patient performs physical and occupational therapy exercises by interacting with a number of virtual simulated exercises that are designed in a game-like fashion.

3.1.2.12 AFX⁴⁴

Jones et al. proposed the Actuated Finger Exoskeleton (AFX), which has 3 active DOF for the index finger joints: the MCP (1 DOF), PIP (1 DOF), and DIP (1 DOF), actuated by a cable mechanism driven by electric motors. The three rotational joints of the exoskeleton are aligned with the flexion/extension axes of each joint of the user. The exoskeleton structure is therefore located at the side of the finger. This device is capable of operating in position control mode or torque control mode.

3.1.2.13 IntelliArm⁴⁵

Ren et al. developed a whole arm exoskeleton with a hand part actuated by four bar linkages and electric motors. One active DOF was designed to drive the hand to open/grasp at the MCP and thumb joints in a synchronized opening/closing motion of the hand. An electric motor is used to provide hand opening and closing training.

Passive movement and active assistive exercise are provided with this device. The active assistive exercise mode can improve voluntary neuromuscular control by using games with a gripping task.

3.1.3 Driven by Pneumatic Actuator

3.1.3.1 Hand mentor⁴⁶

The hand mentor is a commercial hand rehabilitation therapy system produced by Kinetic Muscles Inc. (USA). It is a 1 DOF device that provides a controlled resistive force to the hand and wrist. The applied force can oppose flexion or assist extension of the hand. It incorporates sensors that monitor the position of the wrist and fingers during flexion/extension motions, as along with force sensors to measure the force applied to the hand by the compliant air muscle actuator. The device incorporates surface EMG recording electrodes in contact with the patient's muscles and an EMG level display.

3.1.3.2 HWARD⁴⁷

The Hand Wrist Assistive Rehabilitation Device (HWARD) developed by Takahashi et al. is a 3 DOF (1 for fingers, 1 for thumb, and 1 for wrist) pneumatically actuated system that exercises flexion and extension of the hand as well as wrist movement. The device can simultaneously flex and extend the fingers, including the thumb, about the MCP joint. Wrist flexion and extension is also performed. This device can assist with grasping and releasing movements while simultaneously allowing the user to feel real objects during therapy. Three double-acting cylinders are used to drive the device.

3.1.3.3 Wu et al.⁴⁸

Wu et al. developed a hand exoskeleton with 2 active DOF (flexion/extension of the MCP and PIP joints of the fingers,

excluding the thumb). This device provides the assistive forces required for finger training. To enable bidirectional movement at a finger joint with a pneumatic muscle, a PM-TS actuator consisting of a pneumatic muscle and a torsion spring is applied. In this configuration, the torsion spring provides the extension of the pneumatic muscle.

The purpose of the control scheme used in this device is to provide controllable, quantifiable assistance specific to some particular patients by adapting the level of assistance provided.

3.2 Exoskeletons for Assistance

Various works have been conducted for applications in hand function assistance. The purpose of most of these devices is to help the disabled. However, some of the devices were developed to help astronauts, because moving fingers while wearing a space suit glove is difficult because of the stiffness of the glove itself and the pressure difference.

3.2.1 Driven by Electric Actuator

3.2.1.1 Martinez et al.^{49,50}

At the College of New Jersey, a power-assisted exoskeleton has been designed to help the pinching and grasping motion of people with decreased hand functionality caused by disease. Martinez et al. designed an under-actuated cable-driven exoskeleton with active flexion and passive extension mechanisms. There are three actuated fingers: the thumb, index and middle fingers. The middle finger motion acts in conjunction with that of the ring and small fingers. For each finger, flexion is performed using a linear actuator, while extension is performed by a spring. Aluminum bands are located at the circumferences of the phalanges, forming a linkage with connecting structures between the bands. Force sensing resistors (FSR) installed inside the actuated fingers measure the flexion forces for control of the device.

3.2.1.2 Orthotic Hand-Assistive Exoskeleton (OHAE)⁵¹

Baker et al. introduced a project to develop a hand exoskeleton with an active extension capability, unlike the previous exoskeleton designs^{49,50} described above that used springs to extend the fingers. This device has three actuated fingers: the thumb, index and middle fingers, driven by cables attached to a glove. Aluminum bands and carbon fiber rods sewn into the glove build a skeletal structure for finger movement. There is a linear actuator for each finger, which pulls the cable in bidirectional motion to flex and extend the finger. The motion intention of the user is sensed by two force-sensing resistors (FSR) attached at the dorsal and ventral sides of the distal link of each actuated finger. The FSRs are intended to measure the contact forces caused by the user's finger movement.

3.2.1.3 Hasegawa et al.^{52,53} (Fig. 5(a))

Hasegawa et al. have developed an exoskeleton to assist with hand and wrist functions. The device has a total of 11 active DOF: three for the index finger, three for the middle-ring-small finger combination, two for the thumb, and three for the wrist. Although the authors adopted a cable-driven mechanism mimicking human

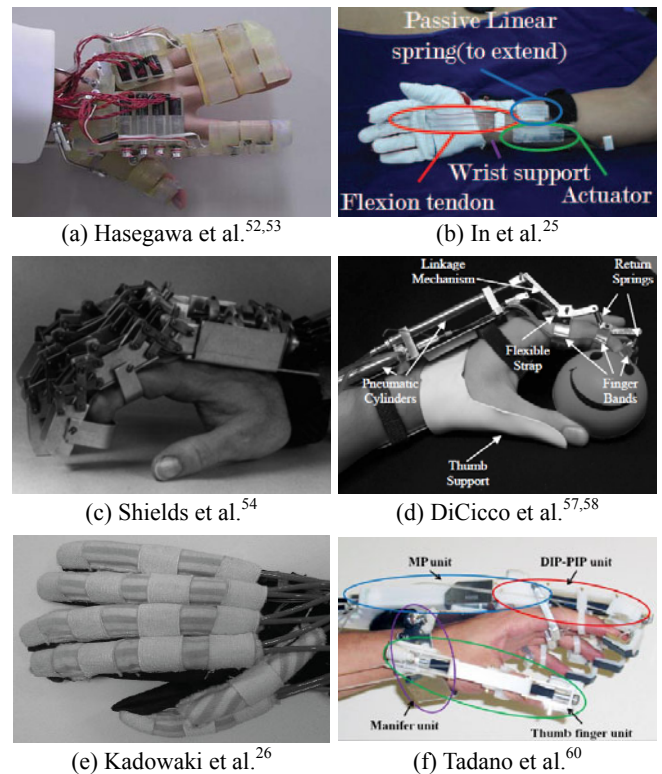

Fig. 5 Some of the hand exoskeletons for assistance

finger motion driven by tendons, there is a difference in that their device controls each joint independently. This method is used to simulate the compliance variation of a human finger according to the grasping force exerted to maintain grasping stability.

The authors proposed a 'dual sensing system' and a 'bioelectric potential-based switching control algorithm' to enable small resistance to movement while providing force augmentation only when the user exerts a relatively large grasping force. The finger joint angles and the bioelectric potential are measured to control the device. The grasping force is estimated from the bioelectric potential measured by surface electrodes on the lumbrical muscles. When the estimated grasping force is below a certain threshold, meaning that the force assistance is not required, the device controls the motors to keep the wires slightly relaxed, regardless of the finger posture. The motor control commands are generated by calculation of the required wire lengths based on the joint angles measured from the exoskeleton. This behavior results in low resistance during unassisted finger movement. However, if the estimated grasping force becomes significantly large, indicating that the user needs force assistance, the control mode of the exoskeleton is switched to the other mode, which controls the grasping force. Using this mode, assistance is given to the index finger while the thumb maintains its current posture.

3.2.1.4 In et al.³⁰

In et al. proposed a glove-type hand exoskeleton to assist disabled people. This device adopts an underactuated cable-driven mechanism attached to a glove. Because there is no rigid linkage, the wearer's hand becomes the linkage structure for operation of the exoskeleton. A cable exerts a flexion force on each finger, while the

extension force is provided passively by a spring. All of the actuated fingers are driven by a single motor. However, the tendon excursions which occur during the finger movements are different for each finger because of the differences in the moment arms. There are therefore stacked pulleys with different diameters at the output shaft of the motor, providing suitable amounts of tendon excursion for each finger. An electromyography (EMG) signal is used to control the device in a simple on-off manner. The device exerts a flexion force when the EMG signal exceeds a predefined threshold.

3.2.1.5 In et al.²⁵ (Fig. 5(b))

After the preceding work³⁰ described above, In et al. developed another hand exoskeleton, adopting a differential mechanism for multi-finger underactuation to substitute for the stacked pulleys with different diameters that were used in the previous model. Like its predecessor, this device uses the user's own hand as a supporting structure for finger movement, because there are no rigid linkages. The flexion motions of the three actuated fingers are performed using a motor, and the extension motions are performed using extension springs.

The differential mechanism enables the device to grasp an object with a three-dimensional surface securely with only one actuator by adjusting the movement of the fingers. The key parts of the proposed differential mechanism are U-shaped tubes located at the fingertips and between the fingers. The tubes at the fingertips move with the fingers, while the tube between the fingers maintains its position. When a spooler attached to a motor pulls the cable for finger flexion, the total exposed length of the flexor cable is shortened, and this causes the flexion of the fingers. When there is no external resistance, the actuated fingers are flexed almost evenly. However, if one finger is blocked by an obstacle, the U-shaped tube of the obstructed finger cannot move any further. On the other hand, shortening of the flexor cable results in faster flexion of an unobstructed finger.

3.2.1.6 Shields et al.⁵⁴ (Fig. 5(c))

Space suits and gloves are stiffened by the pressure difference when they are exposed to the vacuum of space during extravehicular activities (EVA). Because it is difficult for astronauts to move against this stiffness, space suits have caused reduced dexterity and increased fatigue. To overcome this problem, some devices have been developed.

Shields et al. proposed a hand exoskeleton for an EVA glove. It has three actuated fingers (index, middle, ring-small), with one DOF for each finger. The links for each finger form four-bar mechanisms to allow the joints to rotate about remote centers that are coincident with the joints of the wearer's fingers. The motions of the two joints for each finger are coupled together. This device exerts a flexion force generated by motors via a cable-driven cam mechanism, while the extension is performed using a passive force provided by the stiffness of the space suit glove. The user's intention to flex the glove is sensed by force sensors mounted inside each fingertip. The control of the device is performed in a simple

on/off manner with two threshold levels that classify the operation modes into flexion, stop, and extension modes.

3.2.1.7 SkilMate⁵⁵

Yamada et al. proposed a design for a powered hand assistance device for space suit gloves. Three fingers are actuated using the device: the thumb, index, and middle fingers. The largest joint for each finger is actuated by an ultrasonic motor to flex or extend the joint. The device is composed of inner and outer parts corresponding to master and slave devices, respectively. The outer part is controlled to follow the motion of the inner part. The joint angle of each actuated finger is measured using an encoder attached to the inner part.

Because of the importance of tactile information in manipulation, this device is designed to be equipped with tactile sensors and tactile display elements to provide the wearer with tactile information in the form of vibration.

3.2.1.8 Benjuya et al.⁵⁶

Benjuya et al. developed a myoelectric hand orthosis for spinal cord injury patients at the C5-6 level. This device has one actuated DOF at the MCP joint for flexion/extension of the coupled index and middle fingers. A DC motor is located on a forearm band, transmitting power to the fingers through a flexible shaft. The flexible shaft has a worm gear at the distal end so that the shaft rotation drives a spur gear of a finger piece, to which the index and middle fingers are tied. The pinching force is controlled in a manner proportional to the amplitude of the EMG signal from the forearm.

3.2.2 Driven by Pneumatic Actuator

3.2.2.1 DiCicco et al.^{57,58} (Fig. 5(d))

DiCicco et al. developed an orthotic hand exoskeleton for quadriplegic patients with C5/C6 injuries. With this device, a pinching motion is performed by the index finger while the thumb is fixed in an opposed posture. This system has 2 active DOF for the index finger: one for MCP flexion/extension, and the other for coupled PIP/DIP flexion/extension. The flexion of the PIP and DIP joints is controlled using a cable located at the volar side of each finger band. These cables are pulled by a pneumatic cylinder acting in compression. The flexion of the MCP joint is performed by a linkage mechanism driven by a pneumatic cylinder acting in extension. Pressurized air is supplied to the pneumatic cylinders simultaneously. For extension of the joints, springs are mounted at the joints to exert a passive extension force.

Three control strategies are applied for control of the device. First, a binary control algorithm with a simple on/off method based on the EMG signal acquired from the biceps of the contralateral arm can be used. With this control mode, the finger is flexed when the signal level from the contralateral biceps exceeds a certain threshold. The flexed posture is maintained while the signal level remains above the threshold. Second, a method which controls the air pressure continuously relative to the measured EMG signal from the contralateral biceps is applied. Finally, a natural reach and pinch algorithm which uses the EMG signal from the ipsilateral biceps is

used. With the third control mode, the user does not have to concentrate on straining their contralateral arm to control the device.

3.2.2.2 Sasaki et al.⁵⁹

Sasaki et al. developed a wearable power assisted device for grasping functions. The device has five fingers actuated by pneumatic rubber muscles. Each pneumatic muscle is attached directly to the glove, eliminating the usage of a linkage structure. Each finger, except for the thumb, has one active DOF for flexion/extension, while the thumb has 2 active DOF for flexion/extension and for opposing motion.

A curved type rubber muscle is used for the flexion of each finger, including the thumb, while two linear type rubber muscles are used for the opposing movement of the thumb. The curved type rubber muscle is composed of a lengthwise expandable rubber tube with an inelastic fiber tape attached to the side of it. Pressurization of the rubber tube makes the rubber muscle bend. The difference between the linear type rubber muscle and the curved type rubber muscle is the absence of the fiber tape. Therefore, when pressurized, the linear type rubber muscle is extended in the axial direction.

One of the operating methods for the device is on/off control using an expiration switch. When the pressure provided by the user's mouth exceeds a certain threshold, the device is activated for grasping. The other operating method is contact force control using a tactile sensor installed at the index fingertip. The pressure of the supplied air is feedback-controlled by this method.

3.2.2.3 Kadowaki et al.²⁶ (Fig. 5(e))

Kadowaki et al. developed a power-assisted glove for those who have a weak hand grasping force. The actuated DOF are the same as for its predecessor, described above.⁵⁹ This device also adopted pneumatic rubber muscles as actuators. The differences between this device and that of the former work are the types of pneumatic muscles used and the operating method.

Two types of pneumatic rubber muscles are applied: one is a sheet-like curved rubber muscle, and the other is a spiral rubber muscle. The former has a role in the flexion of each finger while the latter makes the opposing motion of the thumb. Because the sheet-like curved rubber muscle has two lengthwise expandable elements located in parallel, the bending direction can be controlled by selecting the element to be pressurized. Both the extension and the flexion are therefore actively performed. The spiral rubber muscle consists of an expandable rubber tube and a cloth which is stretchable in the oblique direction. This makes the spiral muscle twist when it is pressurized.

The glove is controlled by means of finger posture, measured using a data glove or an EMG signal acquired from the forearm muscles. With a data glove equipped with bend sensors, the device can be controlled using the motion of the glove. For the EMG-based control case, the grasping motion commences when the signal level exceeds a certain threshold.

3.2.2.4 Tadano et al.⁶⁰ (Fig. 5(f))

Tadano et al. developed a hand exoskeleton actuated by

pneumatic artificial rubber muscles. Although the device has a total of 10 DOF comprising 2 DOF for each finger, they are underactuated, with one active DOF for each finger. A contracting pneumatic rubber muscle is attached under a bi-articular linkage mechanism for each finger for flexion.

At the fingertip part of each finger, a balloon sensor is installed to sense pressure exerted by the user. The pressure values sensed by the balloon sensors are applied to grasping force control of the device. The device amplifies the grasping force in proportion to the sensed pressure.

3.2.2.5 Takagi et al.⁶¹

Takagi et al. developed a grip aid system using pneumatic cylinders. It has three actuated fingers: the thumb, index, and middle fingers. Each finger is equipped with a pneumatic cylinder at the dorsal part of the finger so that extension of the pneumatic cylinder causes the flexion of the corresponding finger. The linkage mechanisms for the index and middle fingers cause coupled MCP-PIP joint motion.

A bending sensor attached to the small finger measures the flexion angle of the small finger. The sensed bending angle can be used for control of the device.

3.2.2.6 Toya et al.⁶²

Toya et al. developed a power-assisted glove which is controlled based on the estimated grasping intention extracted from the initial movement patterns of the finger joint angles. The device assists all 5 fingers. Each finger has 2 active DOF, apart from the thumb, which has one active DOF. However, the MCP joints of the index, middle, ring, and small fingers are actuated together. The PIP joints of the index and middle fingers are also actuated simultaneously. In the same manner, the PIP joints of the ring and small fingers move together. Only the actuation of the thumb is isolated. Therefore, the actual number of actuated DOF is 4. The actuation is performed using pneumatic soft actuators that bend when pressurized air is supplied.

Unlike other hand assisting exoskeletons, this device performs a predefined motion from 3 grasping motions according to a classification result from analysis of the initial motion of the fingers. The three principal grasping motions applied are a power grip, a precision grip, and a tip pinch. For control of the device, four angle sensors are installed in some of the joints. The angle sensor locations are determined based on the analysis of the initial movement patterns of the finger joint angles for each grasping mode. A pattern classification method is applied to the measured angles to distinguish the movement patterns and to predict the grasping mode.

3.2.2.7 Moromugi et al.⁶³

Moromugi et al. developed a hand exoskeleton actuated by a pneumatic cylinder for assisting with grip force. The device has an actuated index finger with 3 links, where the links are connected together by sublinks so that the motion of the pneumatic cylinder causes synchronized motion at the joints. On the extension of the

cylinder, the exoskeleton performs a gripping motion toward the fixed thumb. The user's intention of motion is sensed using a muscle hardness sensor attached to the forearm. The muscle hardness sensor measures pressure while providing a mechanical indentation on the skin. When the muscle under the sensor is activated, the hardness increment of the muscle causes elevation of the measured pressure.

3.2.3 Driven by Shape Memory Alloy

3.2.3.1 SMART Wrist-Hand Orthosis⁶⁴

Makaran et al. developed an exoskeleton type hand orthosis to help the grasping function of quadriplegic patients. The device has one actuated finger which rotates around the MCP joint axis. A shape memory alloy (SMA) actuator is used as an actuator for the flexion of the finger. Extension is performed by a spring. Because the SMA used has high electric resistance, heat generation by passing an electric current through it is a possible method of operating the SMA actuator.

The device is controlled by using a sip-and-puff switch or an EMG signal. They can be used as commands for on/off operation with appropriately defined thresholds.

4. Actuator Technologies

Different types of actuators have been developed to actuate hand exoskeletons for assistive and rehabilitation purposes. In this section, the conventional exoskeleton actuators (electric motor and pneumatic actuator) and the smart material actuators (shape memory alloy and electroactive polymer) are introduced, and their characteristics are briefly summarized.

4.1 Electric Motors

Electric motors have been used successfully not only as exoskeleton actuators but also as prosthetic finger actuators, because they are easily available, reliable and easy to control. They can be categorized into DC motors and AC motors according to their electric power sources. The AC motor can further be classified as shown in Fig. 6. Synchronous motors using permanent magnets are classified into brushless AC (BLAC) motors and brushless DC (BLDC) motors, depending on the shape of the back electromotive force. More specifically, BLAC and BLDC motors have sinusoidal and trapezoidal back electromotive force shapes, respectively. The BLAC motor system is generally more expensive than the BLDC motor system.⁶⁵⁻⁶⁷

The development of power electronics enables AC motors to be widely used as actuators. The source of the field flux in a synchronous motor can be changed from an electrically excited field winding to a permanent magnet by the use of a high-performance reliable permanent magnet. The use of the permanent-magnet synchronous motor (PMSM) can increase the torque and power density with improved efficiency compared to that of a synchronous motor with an electrically excited field winding.⁶⁶ Gopura et al.⁶⁸ summarized many upper limb exoskeletons actuated

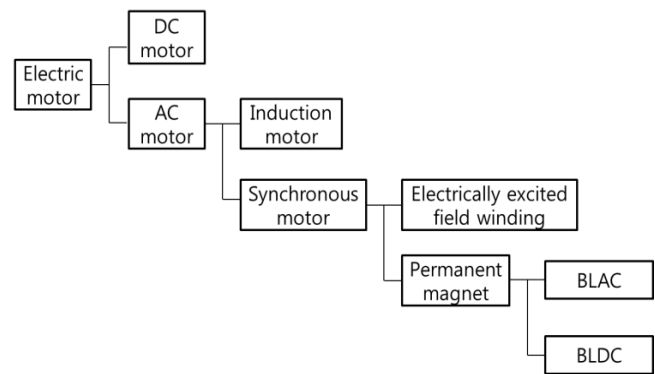

Fig. 6 Classification of electric motors

with electric motors, and they showed a long list of DC or BLDC motors. The DC motor has been extensively used because of the simple structure of the motor itself, as well as that of its electronic drive; however, it requires regular maintenance because of the mechanical contact between the brush and commutator. The BLDC motor not only requires no regular maintenance but also has the advantage of high speed driving because it uses an electronic inverter instead of the brush and commutator. Also, a heavy armature rotates in the DC motor while a light permanent magnet rotates in the BLDC motor; the small inertia of the BLDC motor therefore enables rapid acceleration and deceleration.^{66,67}

To transmit the power of electric motors to each joint of the exoskeletons, transmission mechanisms such as cables, gears and linkages have been used.⁶⁸

4.2 Pneumatic Actuators

Pneumatic actuators have been used in many exoskeleton applications.⁶⁸ The air compressor used to generate the compressed air for pneumatic actuation is both bulky and noisy. The noise problem can be overcome by using pre-compressed air storage. However, the size of the pneumatic system cannot be easily reduced because of the air storage chamber volume. Pneumatic actuators therefore must be used for systems with lower mobility or their bulky parts must be placed in the user's carrying case, such as in a wheelchair.⁵⁸ Cylinders and pneumatic artificial muscles are widely used to transmit the power of compressed air into the exoskeletons.⁶⁸

The McKibben type pneumatic artificial muscle is made of a rubber inner tube covered with a shell braided by helical weaving. When the inner tube is pressurized, the muscle inflates and contracts.⁶⁹ Another commonly used form of pneumatic artificial muscle is the bending type pneumatic muscle. Noritsugu et al. developed a pneumatic rubber muscle consisting of a rubber tube with a bellows sleeve.⁷⁰ One side of the muscle was reinforced with fiber tape to generate a bending motion of the pneumatic muscle by supplying compressed air. To replace the fiber reinforcement of the bending type pneumatic muscle, Takashima et al. used a shape memory polymer (SMP) with an elastic modulus that varied with its temperature.⁷¹ In this pneumatic muscle with SMP, the bending direction could be changed by varying the heating area of the actuator.

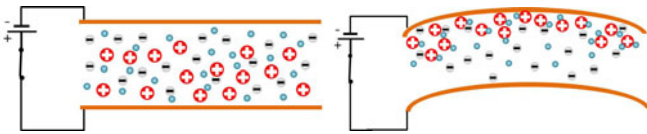

Fig. 7 Structure and bending mechanism of IPMCs. The positive and negative symbols represent cations and anions, and small circles represent water molecules

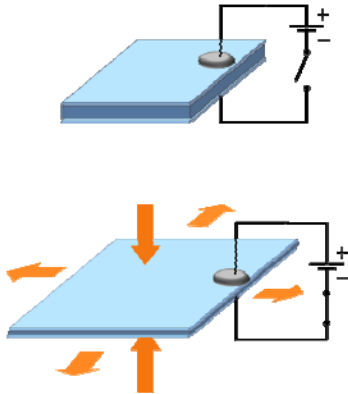

Fig. 8 Structure and actuation mechanism of dielectric elastomer

4.3 Electroactive Polymer Actuator

Though the electroactive polymers (EAPs) are not widely used as actuators for exoskeletons, they are attractive actuators because of their muscle-like nature, such as light weight, flexibility and low power consumption. They can be classified into ionic type and electronic type EAPs. The ionic EAP generates deformations such as expansion, contraction or bending through movement of ions in response to voltage stimulations as low as 1-5 V. Ionic polymer-metal composites (IPMCs), ionic polymer gels, conductive polymers and carbon nanotubes are ionic EAPs. This type of EAP has the advantages of low drive voltage, large bending displacement and natural bi-directional actuation, along with the disadvantages of slow response and a relatively low actuation force.⁷² Fig. 7 shows the typical structure and actuation mechanism of IPMCs. IPMCs consist of an ionic polymer membrane and two surface metal electrodes. When a low voltage is applied to the two electrodes (anode and cathode), cations in the polyelectrolyte move towards the cathode; the cathode side therefore swells while the other side shrinks, which results in the bending deformation.⁷³ Bar-Cohen introduced a 4 finger gripper lifting a rock as a robotic application of IPMCs.⁷⁴ Also, Deole et al. developed an IPMC microgripper to manipulate micro-sized objects.⁷⁵ This IPMC actuator does not require a power transmission mechanism for hand exoskeleton applications because it generates a natural bending motion like the aforementioned pneumatic muscle.

In contrast to the ionic EAP, the electronic EAP is driven by an electric field or by Coulomb forces. Dielectric elastomers, ferroelectric polymers and electrostrictive graft elastomers are types of electronic EAP. This type of EAP has the advantages of rapid response and a relatively large actuation force; however, it requires heavy components such as high voltage transformers and has potential problems related to safety issues and material breakdown because of the high actuation voltage.^{72,73,76} Fig. 8 shows the

structure and actuation mechanism of a dielectric elastomer. The dielectric elastomer consists of a dielectric film with two surface electrodes. When a high voltage is applied to the two electrodes, the dielectric film becomes thinner, which results in its lateral expansion.^{73,77} Herr et al. introduced the application of a dielectric elastomer to act as a bicep on a full size skeletal muscle.⁷⁸ This dielectric actuator needs a power transmission mechanism to be used for a hand exoskeleton because it yields a linear motion.

4.4 Shape Memory Alloy Actuator

The shape memory alloy (SMA) actuator utilizes the shape memory effect (SME), which indicates the property of recovering the original shape upon heating to a critical temperature when it is deformed in the low temperature phase.⁷⁹ The materials that can be used as SMA include Ni-Ti and Cu-Al-Ni, but several other combinations exist. The SME occurs by the shift of crystalline structure between two phases, martensite and austenite. It is in martensite phase when the temperature is low. Heating above the transition temperature makes it recover the original shape with returning to the austenite phase.⁸⁰

Because of the unique property and the high power-to-weight ratio, they are being used for wide applications as both actuators and sensors. However, the high nonlinearity including hysteresis and saturation make the precise control of the SMA actuator difficult.

5. Intention Sensing Methods

For assistive hand exoskeletons, accurate sensing of the user's intended motion is a primary concern. For the purposes of controlling a device or ergonomic evaluation, there have been various methods for detection of motion intention. The applied techniques range from direct measurement of contact force to estimation of the exerted force from biomechanical signals.

The methods mentioned below contain not only methods that have already been applied to hand exoskeletons, but also those that have not been applied yet. The latter methods have either been adopted in other interactive devices or have potential for usage in hand exoskeletons. In fact, the intention sensing methods can be used as a general means of device control.

5.1 Force Sensing

One of the most direct methods of sensing a user's intention is to measure the force exerted by the user at the interface. This method has been applied to several hand exoskeletons for assistance applications.^{49-51,54,59,60} The sensing is usually performed at the fingertip. Although it may obstruct the haptic sensation of the user's finger by preventing the finger from contacting an object which is to be manipulated, it is the most reliable method for control of the grasping force. Also, obstruction of the haptic sensation is not a problem for assistive devices for EVA gloves. For measurement of the contact force, force sensing resistors (FSRs), pneumatic pressure sensors, and strain gauge sensors are predominantly used.

5.2 Motion Sensing

The bending angle of the finger can be used as an input signal for a position controller to operate a hand exoskeleton.^{26,55,61,62} However, because the bending angle of the finger should be induced by the user's motion, hand exoskeletons of this type usually have a master-slave configuration. In this case, the master device is closely attached to the user's finger to measure the finger posture. The slave device, which is the assistive hand exoskeleton, follows the posture of the master device when the movement of the master device occurs. The hand exoskeleton can also be controlled by a finger that is not assisted by the device.⁶¹ The initial movement pattern of the user's finger can also be a triggering command for programmed grasping based on a pattern classification technique.⁶² For measurement of the finger movement, a bending sensor or rotary encoder can be used.

5.3 Breath Switch

Though they lack intuitiveness compared to other control methods, breath switches such as an expiration switch or a sip-and-puff switch are also reliable means of controlling the assistive hand exoskeleton.^{59,64} This method is especially useful for patients who have limited ability to control the device with their body motion or activation of their skeletal muscles.

5.4 Surface Electromyography (sEMG)

Electromyography (EMG) is a technique for evaluation and recording of the electrical activity produced by skeletal muscles.⁸¹ In particular, surface electromyography (sEMG) is a noninvasive way to indirectly estimate the muscle activation level. The use of an EMG signal as a command for control of an exoskeleton also has the advantage of eliminating the time delay generated when the exoskeleton reacts to the human intention. This interface at a higher level of the human neurological system makes it possible to overcome the electro-chemical-mechanical delay which inherently exists in the musculoskeletal system.⁸² The time delay is the time between the activation of the neural system and the actual onset of movement of the muscles and the corresponding joints. When the EMG signal is used as a command input for device control, the controller can acquire the neural activation information and process it during the time interval. The collected EMG signal is processed for estimation of the user's intention. The intention estimation, resulting in an estimated joint torque or muscle force, is performed using a suitable model to represent the behavior of the muscle according to the EMG signal. Studies have shown that the torque developed by the related muscles can be estimated from the EMG signal.⁸³⁻⁸⁵

Specifically, the sEMG signal from the forearm muscles has been used for grip force estimation. Linear or nonlinear regression models can be used to estimate the grip force.⁸⁶⁻⁸⁸ Despite the simplicity of these regression models, they can estimate the grip force well. An artificial neural network (ANN) can also be used for the estimation.⁸⁹ The ANN assumes the muscle models as a black box. This approach is useful because not all of the muscles related to the pinch force are located close to the surface, making the

acquisition of the sEMG signal from these muscles difficult. Also, many muscles contribute to the pinch force generation,⁹⁰ causing crosstalk of the signals from the active muscles.^{91,92}

However, using sEMG has some difficulties:⁹³ Because the electrical potentials measured by sEMG are very weak, measurement requires careful electrode placement and excellent contact with the skin. The skin humidity and electrode location can also affect the measurement results greatly.

5.5 Muscle Hardness

The contraction of a muscle causes an increment in the muscle hardness. Acquiring the muscle hardness by measuring the pressure under a certain skin deformation caused by a mechanical indentation can thus be used as a command to control a device.⁶³ Also, the muscle hardness change results in an alteration of the natural frequency of the muscle. This change in natural frequency, measured while providing oscillation with a vibrating element like a piezoelectric material, can be regarded as a signal of muscle activation.⁹⁴

5.6 Mechanomyography (MMG)

Mechanomyography (MMG) is a recording of the oscillations which reflect the mechanical activities of the contracting muscle caused by lateral dimensional changes of the active muscle fibers.⁹⁵ Because the MMG signal reflects the number of recruited motor units and their firing rates, it can be used to estimate the force exerted by the skeletal muscles.⁹⁶

The use of MMG has some advantages over EMG. The placement of the MMG sensor does not need to be precisely selected.⁹⁷ Also, MMG is not influenced by changes in the skin impedance caused by sweat, because it is a mechanical signal.⁹⁸ However, the non-stationary characteristics⁹⁹ and nonlinearity¹⁰⁰ make it difficult to use simple models for estimation of muscle force from MMG signals. Rather than adopt regression models, ANN was used to estimate the muscle force.¹⁰¹

5.7 Photoplethysmography at Fingernail

The change of fingernail color that occurs when a human exerts a gripping force can be used as a fingertip contact force sensor.¹⁰² When the fingertip contact force increases, the blood flow at the fingertip is altered. This alteration of the hemodynamic state results in modification of the fingernail color pattern. The color pattern change is characteristically nonuniform along the length of the fingernail. These fingernail color patterns can be acquired by photodetectors receiving the light from arrays of micro LEDs reflected from the fingernail.

5.8 Fingerpad Deformation

When a fingertip is in contact with an object, the exerted gripping force causes deformation of the fingertip skin. This deformation can also be used as a contact force sensor.¹⁰³ The sensor is designed to be mounted on a fingernail without disturbing the haptic sensation at the fingertip. The width of the fingertip is monitored using a strain gauge sensor.

5.9 Pressure Pattern (Force Myography)

A cuff with arrays of pressure sensors surrounding the forearm can be used to register the distributed mechanical force caused by the activation of the muscles. The pressures on the sensors are generated by volumetric changes in the underlying musculotendinous complex. From this force myography (FMG), individual finger movements can be encoded at the forearm in form of images for the control of robotic and virtual hands for amputees.¹⁰⁴⁻¹⁰⁸ Grip force can also be estimated from the summed and rectified FMG signals of the forearm.¹⁰⁹

6. Conclusions

With the advent of an aging society all over the world, there will be increased demand for the practical application of assistance and rehabilitation technologies. Among the various possible body parts, the hand may be the last endeavor for researchers because of the many degrees of freedom and the number of tactile sensors in the relatively small size of the part.

Several research studies on hand exoskeletons have been introduced in this paper. A summary of the fundamental technologies and challenges in the current research has also been presented. It is promising that there are already some commercialized hand exoskeletons for rehabilitation applications. However, the development of assistive hand exoskeletons still has many challenges to be overcome for practical usage.

It can be seen from our survey that most of the advanced work in this field has been done in recent decades and many of the outcomes have been demonstrated in a laboratory setting and in wired environments. Because not all of the technical components are well developed enough or packaged for use in daily life and in outdoors applications, a considerable amount of cooperative work and use of resources from medical technology, biomechanics, engineering, and product development are required. For outdoor use in particular, power source technologies and reliable wireless technologies must be resolved. In fact, ensuring the portability of the hand exoskeleton system is possibly the most challenging part of the development.

This paper is intended to increase the focus on the hand rehabilitation and assistance device as an independent product and provide the list of challenges in this area to enhance such small and powerful devices.

ACKNOWLEDGEMENT

This research was supported by the Happy tech. program through the National Research Foundation of Korea (NRF) funded by the Ministry of Education, Science and Technology (No. 2011-0020937).

REFERENCES

1. Reinkensmeyer, D. J., Emken, J. L. and Cramer, S. C., "Robotics, motor learning, and neurologic recovery," Annual Review of Biomedical Engineering, Vol. 6, pp. 497-525, 2004.
2. Taub, E., Miller, N., Novack, T., Cook, E., Fleming, W., Nopomuceno, C., Connell, J. and Crago, J., "Technique to improve chronic motor deficit after stroke," Archives of Physical Medicine and Rehabilitation, Vol. 74, No. 4, pp. 347-354, 1993.
3. Mark, V. W. and Taub, E., "Constraint-induced movement therapy for chronic stroke hemiparesis and other disabilities," Restorative Neurology and Neuroscience, Vol. 22, No. 3-5, pp. 317-336, 2004.
4. Patton, J. L. and Mussa-Ivaldi, F. A., "Robot-assisted adaptive training: custom force fields for teaching movement patterns," IEEE Transactions on Biomedical Engineering, Vol. 51, No. 4, pp. 636-646, 2004.
5. Heller, A., Wade, D. T., Wood, V. A., Sunderland, A., Hewer, R. L. and Ward, E., "Arm function after stroke: measurement and recovery over the first three months," Journal of Neurology, Neurosurgery, and Psychiatry, Vol. 50, No. 6, pp. 714-719, 1987.
6. Wade, D. T., Langton-Hewer, R., Wood, V. A., Skilbeck, C. E. and Ismail, H. M., "The hemiplegic arm after stroke: measurement and recovery," Journal of Neurology, Neurosurgery, and Psychiatry, Vol. 46, No. 6, pp. 521-524, 1983.
7. Sunderland, A., Tinson, D., Bradley, L. and Hewer, R. L., "Arm function after stroke. An evaluation of grip strength as a measure of recovery and a prognostic indicator," Journal of Neurology, Neurosurgery, and Psychiatry, Vol. 52, No. 11, pp. 1267-1272, 1989.
8. Nakayama, H., Jorgensen, H., Raaschou, H. and Olsen, T., "Recovery of upper extremity function in stroke patients: the Copenhagen Stroke Study," Archives of Physical Medicine and Rehabilitation, Vol. 75, No. 4, pp. 394-398, 1994.
9. Kapandji, I. A., "The physiology of the joints: annotated diagrams of the mechanics of the human joints," Churchill Livingstone, 1987.
10. Moran, C. A., "Anatomy of the Hand," Physical Therapy, Vol. 69, No. 12, pp. 1007-1013, 1989.
11. Berme, N., Paul, J. P. and Purves, W. K., "A biomechanical analysis of the metacarpo-phalangeal joint," Journal of Biomechanics, Vol. 10, No. 7, pp. 409-412, 1977.
12. Lluch, A., "Intrinsic causes of stiffness of the interphalangeal joints, in: Copeland, S. A., Gschwend, N., Landi, A. and Saffar, P. (Eds.), Joint Stiffness of the Upper Limb," Taylor & Francis, pp. 259-264, 1997.
13. Kapandji, I. A., "The Physiology of the Joints - Volume I: Upper Limb, 5th ed.," Churchill Livingstone, 1982.
14. Hollister, A. and Giurintano, D., "Thumb movements, motions,

- and moments,” *Journal of Hand Therapy*, Vol. 8, No. 2, pp. 106-114, 1995.
15. Imaeda, T., An, K. and Cooney, W., “Functional anatomy and biomechanics of the thumb,” *Hand Clinics*, Vol. 8, No. 1, pp. 9-15, 1992.
 16. Barr, A. and Bear-Lehman, J., “Biomechanics of the wrist and hand, in: Nordin, M. and Frankel, V. H. (Eds.), *Basic Biomechanics of the Musculoskeletal System*, 3rd ed.,” Lippincott Williams & Wilkins, pp. 358-387, 2001.
 17. Taylor, C. L. and Schwarz, R. J., “The anatomy and mechanics of the human hand,” *Artificial Limbs*, Vol. 2, No. 2, pp. 22-35, 1955.
 18. Elliot, D. and McGrouther, D. A., “The excursions of the long extensor tendons of the hand,” *The Journal of Hand Surgery: British & European Volume*, Vol. 11, No. 1, pp. 77-80, 1986.
 19. Armstrong, T. J. and Chaffin, D. B., “An investigation of the relationship between displacements of the finger and wrist joints and the extrinsic finger flexor tendons,” *Journal of Biomechanics*, Vol. 11, No. 3, pp. 119-128, 1978.
 20. Kuczynski, K., “The proximal interphalangeal joint: anatomy and causes of stiffness in the fingers,” *Journal of Bone and Joint Surgery-British Volume*, Vol. 50, No. 3, pp. 656-663, 1968.
 21. Shrewsbury, M. and Johnson, R., “Ligaments of the distal interphalangeal joint and the mallet position,” *The Journal of Hand Surgery*, Vol. 5, No. 3, pp. 214-216, 1980.
 22. Worsnopp, T. T., Peshkin, M. A., Colgate, J. E. and Kamper, D. G., “An Actuated Finger Exoskeleton for Hand Rehabilitation Following Stroke,” *Proc. of the IEEE International Conference on Rehabilitation Robotics*, pp. 896-901, 2007.
 23. Fontana, M., Dettori, A., Salsedo, F. and Bergamasco, M., “Mechanical design of a novel Hand Exoskeleton for accurate force displaying,” *Proc. of the IEEE International Conference on Robotics and Automation*, pp. 1704-1709, 2009.
 24. Wege, A. and Hommel, G., “Development and control of a hand exoskeleton for rehabilitation of hand injuries,” *Proc. of the IEEE/RSJ International Conference on Intelligent Robots and Systems*, pp. 3046-3051, 2005.
 25. In, H. K., Cho, K.-J., Kim, K. R. and Lee, B. S., “Jointless structure and under-actuation mechanism for compact hand exoskeleton,” *Proc. of the IEEE International Conference on Rehabilitation Robotics*, pp. 1-6, 2011.
 26. Kadowaki, Y., Noritsugu, T., Takaiwa, M., Sasaki, D. and Kato, M., “Development of Soft Power-Assist Glove and Control Based on Human Intent,” *Journal of Robotics and Mechatronics*, Vol. 23, No. 2, pp. 281-291, 2011.
 27. Stergiopoulos, P., Fuchs, P. and Laugeau, C., “Design of a 2-finger hand exoskeleton for VR grasping simulation,” *Proc. of the Eurohaptics*, pp. 80-93, 2003.
 28. Nakagawara, S., Kajimoto, H., Kawakami, N., Tachi, S. and Kawabuchi, I., “An Encounter-Type Multi-Fingered Master Hand Using Circuitous Joints,” *Proc. of the IEEE International Conference on Robotics and Automation*, pp. 2667-2672, 2005.
 29. Wang, J., Li, J., Zhang, Y. and Wang, S., “Design of an exoskeleton for index finger rehabilitation,” *Proc. of the Annual International Conference of the IEEE Engineering in Medicine and Biology Society*, pp. 5957-5960, 2009.
 30. In, H. K. and Cho, K. J., “Compact Hand Exoskeleton Robot for the Disabled,” *Proc. of the International Conference on Ubiquitous Robots and Ambient Intelligence*, 2009.
 31. Brokaw, E. B., Black, I., Holley, R. J. and Lum, P. S., “Hand Spring Operated Movement Enhancer (HandSOME): A Portable, Passive Hand Exoskeleton for Stroke Rehabilitation,” *IEEE Transactions on Neural Systems and Rehabilitation Engineering*, Vol. 19, No. 4, pp. 391-399, 2011.
 32. Otto Bock HealthCare, “WaveFlex Hand CPM Device,” http://www.ottobock.ca/cps/rde/xchg/ob_us_en/hs.xml/15712.html
 33. Patterson Medical, “Kinetec Maestra Portable Hand CPM,” http://www.pattersonmedical.com/app.aspx?cmd=get_product&id=74161
 34. Mulas, M., Folgheraiter, M. and Gini, G., “An EMG-controlled exoskeleton for hand rehabilitation,” *Proc. of the 9th International Conference on Rehabilitation Robotics*, pp. 371-374, 2005.
 35. Tong, K. Y., Ho, S. K., Pang, P. M. K., Hu, X. L., Tam, W. K., Fung, K. L., Wei, X. J., Chen, P. N. and Chen, M., “An intention driven hand functions task training robotic system,” *Proc. of the Annual International Conference of the IEEE Engineering in Medicine and Biology Society*, pp. 3406-3409, 2010.
 36. Iqbal, J., Tsagarakis, N. G., Fiorilla, A. E. and Caldwell, D. G., “A portable rehabilitation device for the Hand,” *Proc. of the Annual International Conference of the IEEE Engineering in Medicine and Biology Society*, pp. 3694-3697, 2010.
 37. Schabowsky, C., Godfrey, S., Holley, R. and Lum, P., “Development and pilot testing of HEXORR: Hand EXOskeleton Rehabilitation Robot,” *Journal of NeuroEngineering and Rehabilitation*, Vol. 7, No. 1, p. 36, 2010.
 38. Chiri, A., Giovacchini, F., Vitiello, N., Cattin, E., Roccella, S., Vecchi, F. and Carrozza, M. C., “HANDEXOS: Towards an exoskeleton device for the rehabilitation of the hand,” *Proc. of the IEEE/RSJ International Conference on Intelligent Robots and Systems*, pp. 1106-1111, 2009.
 39. Chiri, A., Vitiello, N., Giovacchini, F., Roccella, S., Vecchi, F.

- and Carrozza, M. C., "Mechatronic Design and Characterization of the Index Finger Module of a Hand Exoskeleton for Post-stroke Rehabilitation," *IEEE/ASME Transactions on Mechatronics*, Vol. PP, No. 99, pp. 1-11, 2011.
40. Wege, A. and Zimmermann, A., "Electromyography sensor based control for a hand exoskeleton," *Proc. of the IEEE International Conference on Robotics and Biomimetics*, pp. 1470-1475, 2007.
 41. Ueki, S., Kawasaki, H., Ito, S., Nishimoto, Y., Abe, M., Aoki, T., Ishigure, Y., Ojika, T. and Mouri, T., "Development of a Hand-Assist Robot With Multi-Degrees-of-Freedom for Rehabilitation Therapy," *IEEE/ASME Transactions on Mechatronics*, Vol. 17, No. 1, pp. 136-146, 2012.
 42. Li, J., Zheng, R., Zhang, Y. and Yao, J., "iHandRehab: An interactive hand exoskeleton for active and passive rehabilitation," *Proc. of the IEEE International Conference on Rehabilitation Robotics*, pp. 1-6, 2011.
 43. Sarakoglou, I., Tsagarakis, N. G. and Caldwell, D. G., "Occupational and physical therapy using a hand exoskeleton based exerciser," *Proc. of the IEEE/RSJ International Conference on Intelligent Robots and Systems*, Vol. 3, pp. 2973-2978, 2004.
 44. Jones, C. L., Wang, F., Osswald, C., Kang, X., Sarkar, N. and Kamper, D. G., "Control and kinematic performance analysis of an Actuated Finger Exoskeleton for hand rehabilitation following stroke," *Proc. of the 3rd IEEE RAS and EMBS International Conference on Biomedical Robotics and Biomechatronics*, pp. 282-287, 2010.
 45. Ren, Y., Park, H.-S. and Zhang, L.-Q., "Developing a whole-arm exoskeleton robot with hand opening and closing mechanism for upper limb stroke rehabilitation," *Proc. of the IEEE International Conference on Rehabilitation Robotics*, pp. 761-765, 2009.
 46. Kinetic Muscles Inc., "Hand Physical Therapy with The Hand Mentor™," <http://www.kineticmuscles.com/hand-physical-therapy-hand-mentor.html>
 47. Takahashi, C. D., Der-Yeghiaian, L., Le, V., Motiwala, R. R. and Cramer, S. C., "Robot-based hand motor therapy after stroke," *Brain*, Vol. 131, No. 2, pp. 425-437, 2008.
 48. Wu, J., Huang, J., Wang, Y. and Xing, K., "A Wearable Rehabilitation Robotic Hand Driven by PM-TS Actuators, in: Liu, H., Ding, H., Xiong, Z. and Zhu, X. (Eds.), *Intelligent Robotics and Applications*," Springer, Vol. 6425, pp. 440-450, 2010.
 49. Martinez, L. A., Olaloye, O. O., Talarico, M. V., Shah, S. M., Arends, R. J. and BuSha, B. F., "A power-assisted exoskeleton optimized for pinching and grasping motions," *Proc. of the IEEE Annual Northeast Bioengineering Conference*, pp. 1-2, 2010.
 50. Rotella, M. F., Reuther, K. E., Hofmann, C. L., Hage, E. B. and BuSha, B. F., "An orthotic hand-assistive exoskeleton for actuated pinch and grasp," *Proc. of the IEEE Annual Northeast Bioengineering Conference*, pp. 1-2, 2009.
 51. Baker, M. D., McDonough, M. K., McMullin, E. M., Swift, M. and BuSha, B. F., "Orthotic Hand-Assistive Exoskeleton," *Proc. of the IEEE 37th Annual Northeast Bioengineering Conference*, pp. 1-2, 2011.
 52. Hasegawa, Y., Mikami, Y., Watanabe, K. and Sankai, Y., "Five-fingered assistive hand with mechanical compliance of human finger," *Proc. of the IEEE International Conference on Robotics and Automation*, pp. 718-724, 2008.
 53. Hasegawa, Y., Tokita, J., Kamibayashi, K. and Sankai, Y., "Evaluation of fingertip force accuracy in different support conditions of exoskeleton," *Proc. of the IEEE International Conference on Robotics and Automation*, pp. 680-685, 2011.
 54. Shields, B. L., Main, J. A., Peterson, S. W. and Strauss, A. M., "An anthropomorphic hand exoskeleton to prevent astronaut hand fatigue during extravehicular activities," *Proc. of the IEEE Transactions on Systems, Man and Cybernetics, Part A: Systems and Humans*, Vol. 27, No. 5, pp. 668-673, 1997.
 55. Yamada, Y., Morizono, T., Sato, S., Shimohira, T., Umetani, Y., Yoshida, T. and Aoki, S., "Proposal of a SkillMate finger for EVA gloves," *Proc. of the IEEE International Conference on Robotics and Automation*, Vol. 2, pp. 1406-1412, 2001.
 56. Benjuya, N. and Kenney, S. B., "Myoelectric Hand Orthosis," *Journal of Prosthetics and Orthotics*, Vol. 2, No. 2, pp. 149-154, 1990.
 57. DiCicco, M., Lucas, L. and Matsuoka, Y., "Comparison of control strategies for an EMG controlled orthotic exoskeleton for the hand," *Proc. of the IEEE International Conference on Robotics and Automation*, Vol. 2, pp. 1622-1627, 2004.
 58. Lucas, L., DiCicco, M. and Matsuoka, Y., "An EMG-controlled hand exoskeleton for natural pinching," *Journal of Robotics and Mechatronics*, Vol. 16, No. 5, pp. 482-488, 2004.
 59. Sasaki, D., Noritsugu, T., Takaiwa, M. and Yamamoto, H., "Wearable power assist device for hand grasping using pneumatic artificial rubber muscle," *Proc. of the IEEE International Workshop on Robot and Human Interactive Communication*, pp. 655-660, 2004.
 60. Tadano, K., Akai, M., Kadota, K. and Kawashima, K., "Development of grip amplified glove using bi-articular mechanism with pneumatic artificial rubber muscle," *Proc. of the IEEE International Conference on Robotics and Automation*, pp. 2363-2368, 2010.
 61. Takagi, M., Iwata, K., Takahashi, Y., Yamamoto, S. I., Koyama, H. and Komeda, T., "Development of a grip aid system using air cylinders," *Proc. of the IEEE International*

- Conference on Robotics and Automation, pp. 2312-2317, 2009.
62. Toya, K., Miyagawa, T. and Kubota, Y., "Power-Assist Glove Operated by Predicting the Grasping Mode," *Journal of System Design and Dynamics*, Vol. 5, No. 1, pp. 94-108, 2011.
 63. Moromugi, S., Koujina, Y., Arika, S., Okamoto, A., Tanaka, T., Feng, M. Q. and Ishimatsu, T., "Muscle stiffness sensor to control an assistance device for the disabled," *Artificial Life and Robotics*, Vol. 8, No. 1, pp. 42-45, 2004.
 64. Makaran, J. E., Dittmer, D. K., Buchal, R. O. and MacArthur, D. E., "The SMART Wrist-Hand Orthosis (WHO) for Quadriplegic Patients," *Journal of Prosthetics and Orthotics*, Vol. 5, No. 3, pp. 73-76, 1993.
 65. Vas, P., "Sensorless vector and direct torque control," Oxford University Press, 1998.
 66. Sul, S. K., "Control of electric machine drive systems," Wiley-IEEE Press, 2011.
 67. Kim, S. H., "DC, AC, BLDC motor control," Bogdoo, 2010.
 68. Gopura, R. A. R. C. and Kiguchi, K., "Mechanical designs of active upper-limb exoskeleton robots: State-of-the-art and design difficulties," *Proc. of the IEEE International Conference on Rehabilitation Robotics*, pp. 178-187, 2009.
 69. Tondu, B. and Lopez, P., "Modeling and control of McKibben artificial muscle robot actuators," *IEEE Control Systems Magazine*, Vol. 20, No. 2, pp. 15-38, 2000.
 70. Noritsugu, T., Takaiwa, M. and Sasaki, D., "Development of power assist wear using pneumatic rubber artificial muscles," *Journal of Robotics and Mechatronics*, Vol. 21, No. 5, pp. 607-613, 2009.
 71. Takashima, K., Noritsugu, T., Rossiter, J., Guo, S. and Mukai, T., "Development of curved type pneumatic artificial rubber muscle using shape-memory polymer," *Proc. of the SICE Annual Conference*, pp. 1691-1695, 2011.
 72. Bar-Cohen, Y., "EAP as artificial muscles: progress and challenges," *Proc. of the Smart Structures and Materials 2004: Electroactive Polymer Actuators and Devices (EAPAD)*, Vol. 5385, pp. 10-16, 2004.
 73. Mirfakhrai, T., Madden, J. D. W. and Baughman, R. H., "Polymer artificial muscles," *Materials Today*, Vol. 10, No. 4, pp. 30-38, 2007.
 74. Bar-Cohen, Y., "Electro-active polymers: current capabilities and challenges," *Proc. of the SPIE, the International Society for Optical Engineering*, Vol. 4695, pp. 1-7, 2002.
 75. Deole, U., Lumia, R., Shahinpoor, M. and Bermudez, M., "Design and test of IPMC artificial muscle microgripper," *Journal of Micro-Nano Mechatronics*, Vol. 4, No. 3, pp. 95-102, 2008.
 76. Abolfathi, P. P., "Development of an Instrumented and Powered Exoskeleton for the Rehabilitation of the Hand," Ph.D. Thesis, School of Aerospace, Mechanical and Mechatronic Engineering, University of Sydney, 2007.
 77. Duncheon, C., "Robots will be of service with muscles, not motors," *Industrial Robot: An International Journal*, Vol. 32, No. 6, pp. 452-455, 2005.
 78. Herr, H. and Kornbluh, R., "New horizons for orthotic and prosthetic technology: artificial muscle for ambulation," *Proc. of SPIE*, Vol. 5385, pp. 1-9, 2004.
 79. Otsuka, K. and Wayman, C. M., "Shape memory materials," Cambridge University Press, 1999.
 80. Mavroidis, C., Pfeiffer, C. and Mosley, M., "Conventional Actuators, Shape Memory Alloys and Electrorheological Fluids," in: Bar-Cohen, Y. (Ed.), *Invited Chapter in Automation, Miniature Robotics and Sensors for Non-Destructive Testing and Evaluation*, The American Society for Nondestructive Testing, pp. 189-214, 2000.
 81. Kamen, G., "Electromyographic Kinesiology," in: Robertson, D. G. E. (Ed.), *Research Methods in Biomechanics*, Human Kinetics, 2004.
 82. Rosen, J., Brand, M., Fuchs, M. B. and Arcan, M., "A myosignal-based powered exoskeleton system," *IEEE Transactions on Systems, Man and Cybernetics, Part A: Systems and Humans*, Vol. 31, No. 3, pp. 210-222, 2001.
 83. Triolo, R. J. and Moskowitz, G. D., "The theoretical development of a multichannel time-series myoprocessor for simultaneous limb function detection and muscle force estimation," *IEEE Transactions on Biomedical Engineering*, Vol. 36, No. 10, pp. 1004-1017, 1989.
 84. Clancy, E. A. and Hogan, N., "Relating agonist-antagonist electromyograms to joint torque during isometric, quasi-isotonic, nonfatiguing contractions," *IEEE Transactions on Biomedical Engineering*, Vol. 44, No. 10, pp. 1024-1028, 1997.
 85. Nam, Y. S., Kim, S. N. and Baek, S.-R., "Calculation of Knee Joint Moment in Isometric and Isokinetic Knee Motion," *Int. J. Precis. Eng. Manuf.*, Vol. 12, No. 5, pp. 921-924, 2011.
 86. Duque, J., Masset, D. and Malchaire, J., "Evaluation of handgrip force from EMG measurements," *Applied Ergonomics*, Vol. 26, No. 1, pp. 61-66, 1995.
 87. Hoozemans, M. J. M. and van Dieën, J. H., "Prediction of handgrip forces using surface EMG of forearm muscles," *Journal of Electromyography and Kinesiology*, Vol. 15, No. 4, pp. 358-366, 2005.
 88. DiDomenico, A. and Nussbaum, M. A., "Estimation of forces exerted by the fingers using standardised surface electromyography from the forearm," *Ergonomics*, Vol. 51, No. 6, pp. 858-871, 2008.

89. Choi, C., Kwon, S., Park, W., Lee, H. and Kim, J., "Real-time pinch force estimation by surface electromyography using an artificial neural network," *Medical Engineering and Physics*, Vol. 32, No. 5, pp. 429-436, 2010.
90. Yu, H. L., Chase, R. A. and Strauch, B., "Atlas of hand anatomy and clinical implications," Mosby Inc., 2004.
91. De Luca, C. J. and Merletti, R., "Surface myoelectric signal cross-talk among muscles of the leg," *Electroencephalography and Clinical Neurophysiology*, Vol. 69, No. 6, pp. 568-575, 1988.
92. Martin, B. J., Armstrong, T. J., Foulke, J. A., Natarajan, S., Klinenberg, E., Serina, E. and Rempel, D., "Keyboard Reaction Force and Finger Flexor Electromyograms during Computer Keyboard Work," *Human Factors: The Journal of the Human Factors and Ergonomics Society*, Vol. 38, No. 4, pp. 654-664, 1996.
93. Lukowicz, P., Hanser, F., Szubski, C. and Schobersberger, W., "Detecting and Interpreting Muscle Activity with Wearable Force Sensors," *Pervasive Computing*, Vol. 3968, pp. 101-116, 2006.
94. Kasuya, M., Seki, M., Kawamura, K. and Fujie, M. G., "Subtle grip force estimation from EMG and muscle stiffness — Relationship between muscle character frequency and grip force," *Proc. of the Annual International Conference of the IEEE Engineering in Medicine and Biology Society*, pp. 4116-4119, 2011.
95. Barry, D. T. and Cole, N. M., "Muscle sounds are emitted at the resonant frequencies of skeletal muscle," *IEEE Transactions on Biomedical Engineering*, Vol. 37, No. 5, pp. 525-531, 1990.
96. Youn, W. and Kim, J., "Estimation of elbow flexion force during isometric muscle contraction from mechanomyography and electromyography," *Medical and Biological Engineering and Computing*, Vol. 48, No. 11, pp. 1149-1157, 2010.
97. Silva, J., Heim, W. and Chau, T., "A Self-Contained, Mechanomyography-Driven Externally Powered Prosthesis," *Archives of Physical Medicine and Rehabilitation*, Vol. 86, No. 10, pp. 2066-2070, 2005.
98. Xie, H.-B., Zheng, Y.-P. and Guo, J.-Y., "Classification of the mechanomyogram signal using a wavelet packet transform and singular value decomposition for multifunction prosthesis control," *Physiological Measurement*, Vol. 30, No. 5, pp. 441-457, 2009.
99. Akataki, K., Mita, K., Watakabe, M. and Itoh, K., "Mechanomyogram and force relationship during voluntary isometric ramp contractions of the biceps brachii muscle," *European Journal of Applied Physiology*, Vol. 84, No. 1, pp. 19-25, 2001.
100. Madeleine, P., Farina, D., Merletti, R. and Arendt-Nielsen, L., "Upper trapezius muscle mechanomyographic and electromyographic activity in humans during low force fatiguing and non-fatiguing contractions," *European Journal of Applied Physiology*, Vol. 87, No. 4, pp. 327-336, 2002.
101. Youn, W. and Kim, J., "Feasibility of using an artificial neural network model to estimate the elbow flexion force from mechanomyography," *Journal of Neuroscience Methods*, Vol. 194, No. 2, pp. 386-393, 2011.
102. Mascaro, S. A. and Asada, H. H., "Photoplethysmograph fingernail sensors for measuring finger forces without haptic obstruction," *IEEE Transactions on Robotics and Automation*, Vol. 17, No. 5, pp. 698-708, 2001.
103. Nakatani, M., Shiojima, K., Kinoshita, S., Kawasoe, T., Koketsu, K. and Wada, J., "Wearable contact force sensor system based on fingerpad deformation," *Proc. of the IEEE World Haptics Conference*, pp. 323-328, 2011.
104. Abboudi, R. L., Glass, C. A., Newby, N. A., Flint, J. A. and Craelius, W., "A biomimetic controller for a multifinger prosthesis," *IEEE Transactions on Rehabilitation Engineering*, Vol. 7, No. 2, pp. 121-129, 1999.
105. Curcie, D. J., Flint, J. A. and Craelius, W., "Biomimetic finger control by filtering of distributed forelimb pressures," *IEEE Transactions on Neural Systems and Rehabilitation Engineering*, Vol. 9, No. 1, pp. 69-75, 2001.
106. Craelius, W., "The Bionic Man: Restoring Mobility," *Science*, Vol. 295, No. 5557, pp. 1018-1021, 2002.
107. Kuttuva, M., Burdea, G., Flint, J. and Craelius, W., "Manipulation Practice for Upper-Limb Amputees Using Virtual Reality," *Presence: Teleoperators and Virtual Environments*, Vol. 14, No. 2, pp. 175-182, 2005.
108. Phillips, S. L. and Craelius, W., "Residual kinetic imaging: a versatile interface for prosthetic control," *Robotica*, Vol. 23, No. 3, pp. 277-282, 2005.
109. Winingar, M., Kim, N. and Craelius, W., "Pressure signature of the forearm as a predictor of grip force," *Journal of Rehabilitation Research and Development*, Vol. 45, No. 6, pp. 883-892, 2008.