

Diseño de LENOVO	Revisado por	Aprobado por	Fecha	Fecha 30/10/2019	
Órtesis dinámica con aplicación de robótica			Ensamblaje 1.1.final pag dwg		Edición
					Hoja 1 / 1

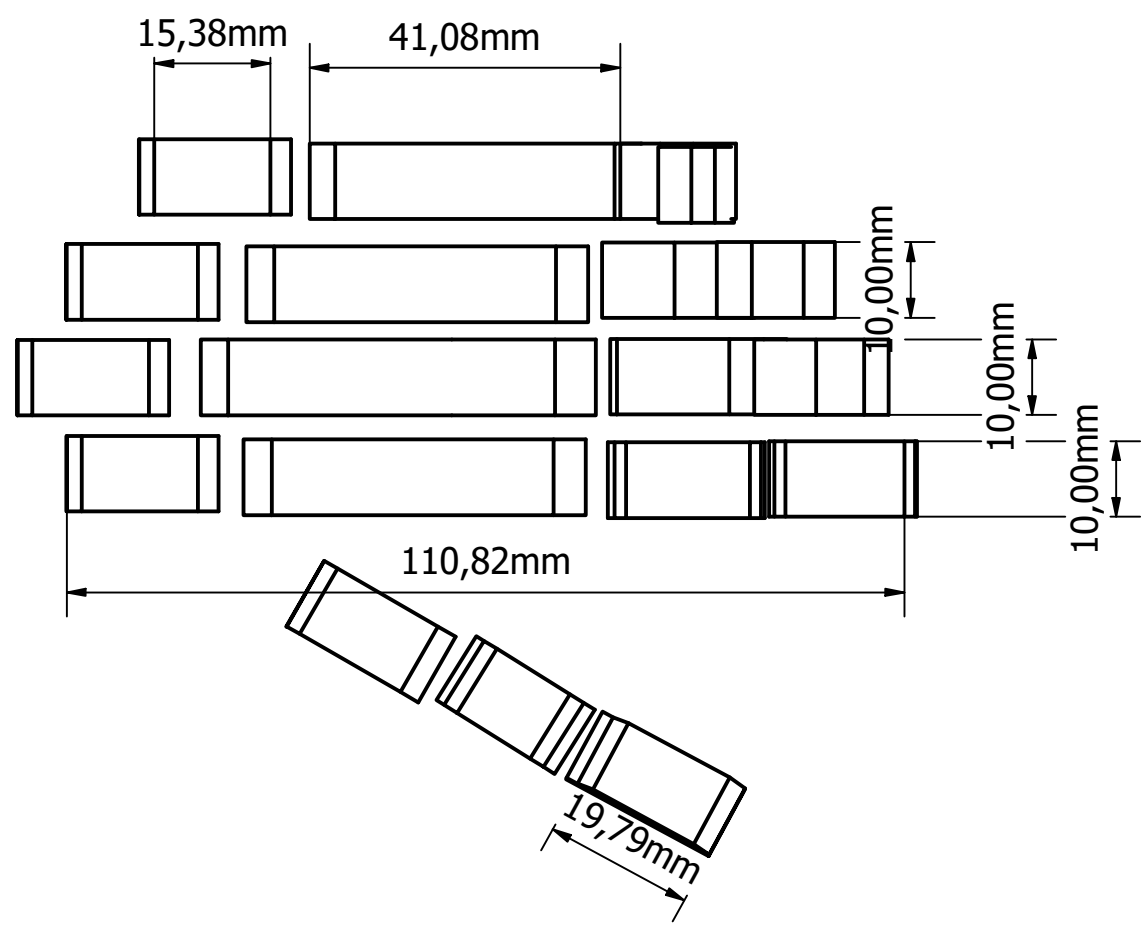

Diseño de LENOVO	Revisado por	Aprobado por	Fecha	Fecha 30/10/2019	
Robótica blanda			Grupo Ursa		
			mano final 3.0	Edición	Hoja 1 / 1

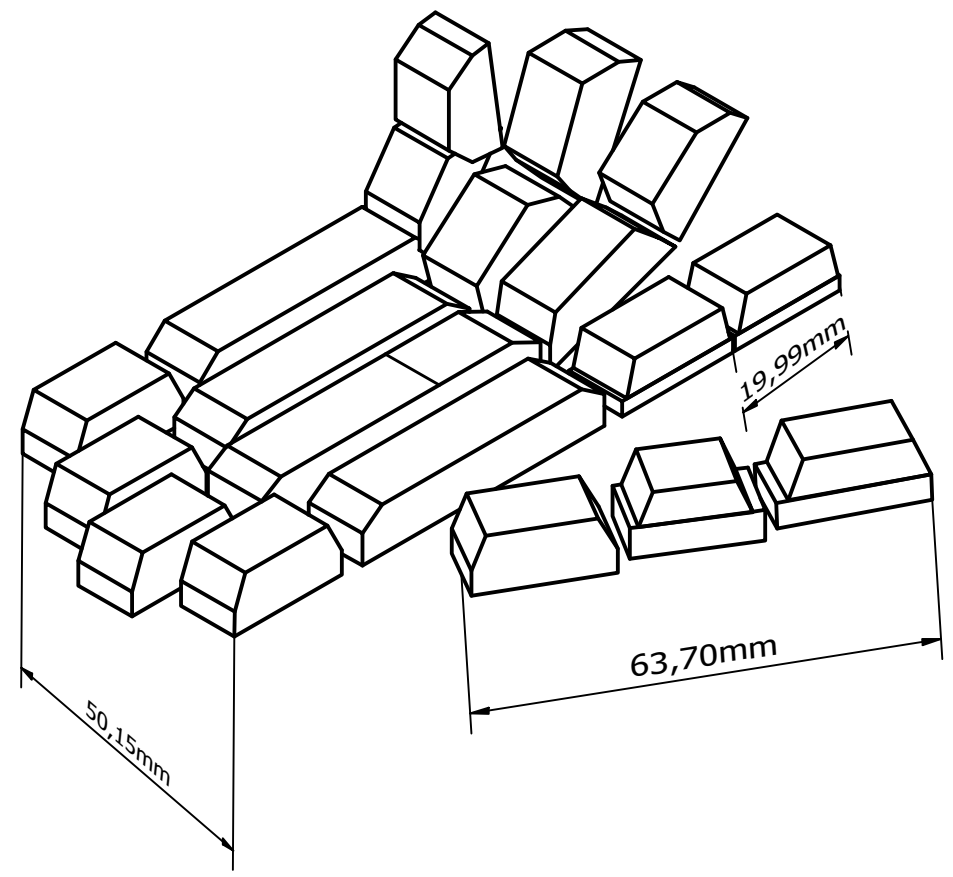
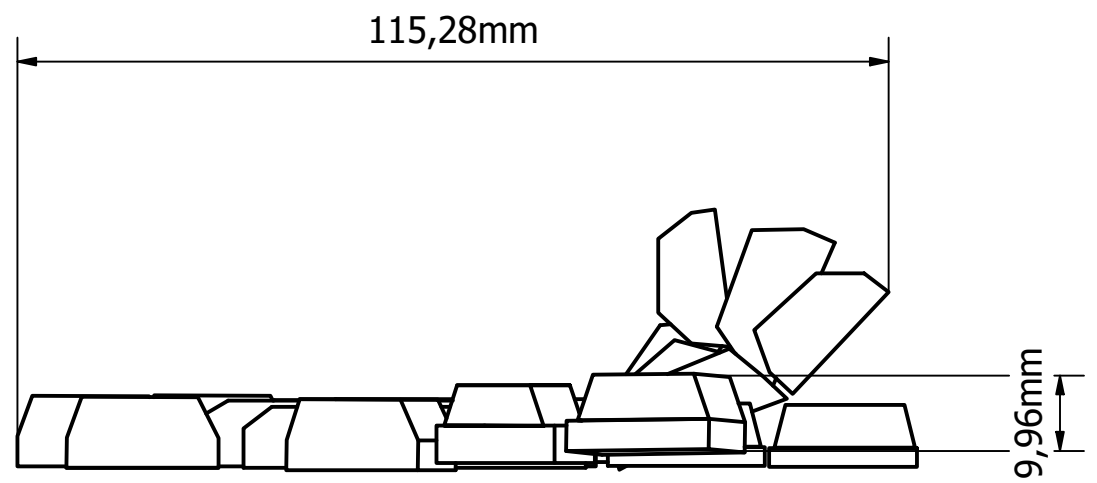
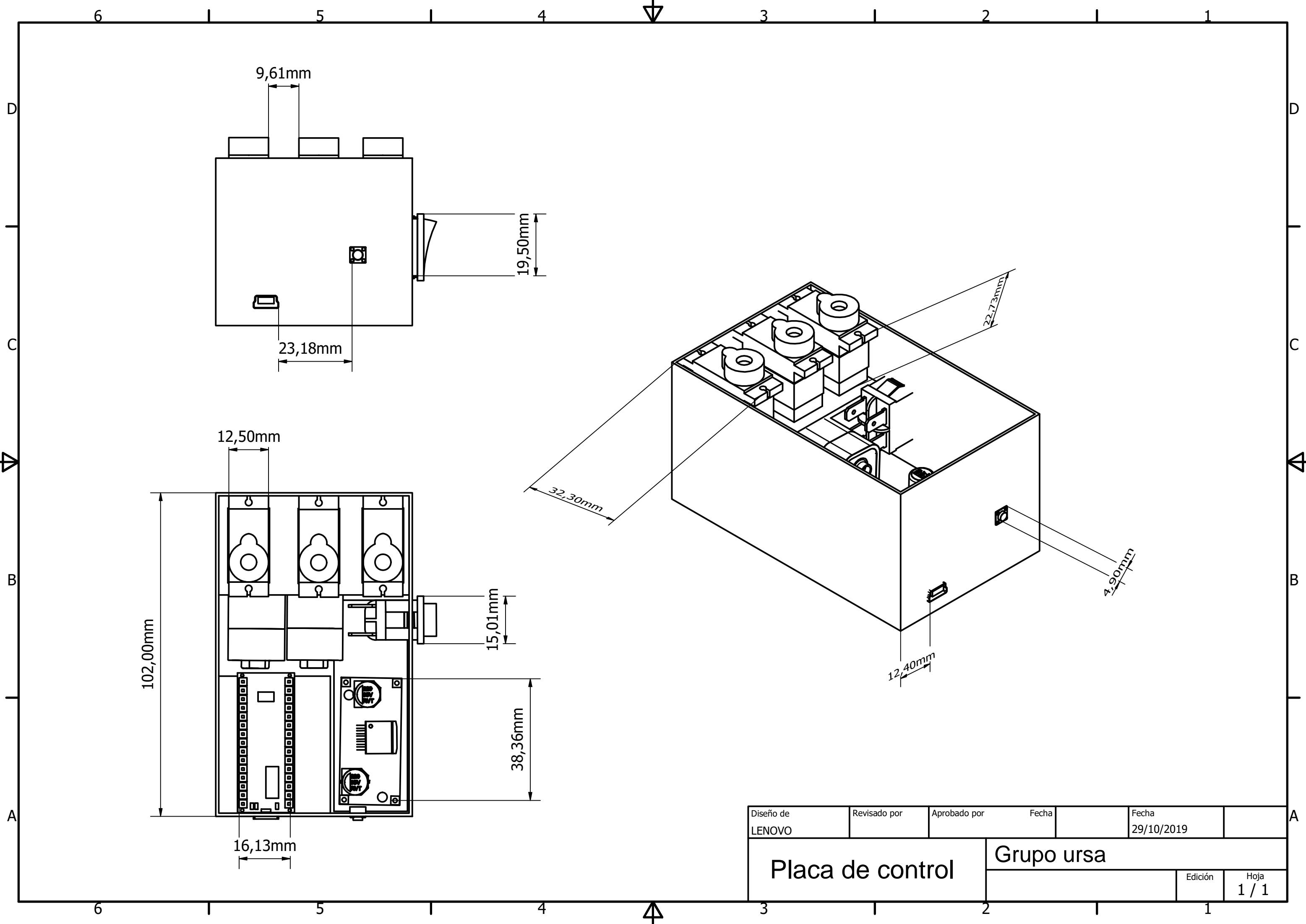

Diseño de LENOVO	Revisado por	Aprobado por	Fecha	Fecha 29/10/2019	
Placa de control			Grupo ursa		
				Edición	Hoja 1 / 1